

FERROXCUBE



c



d



e

f



1 2 3 4 5 6 7 8

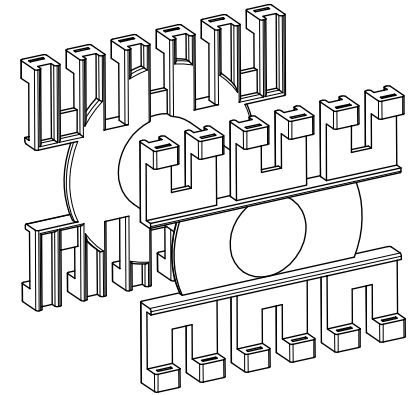
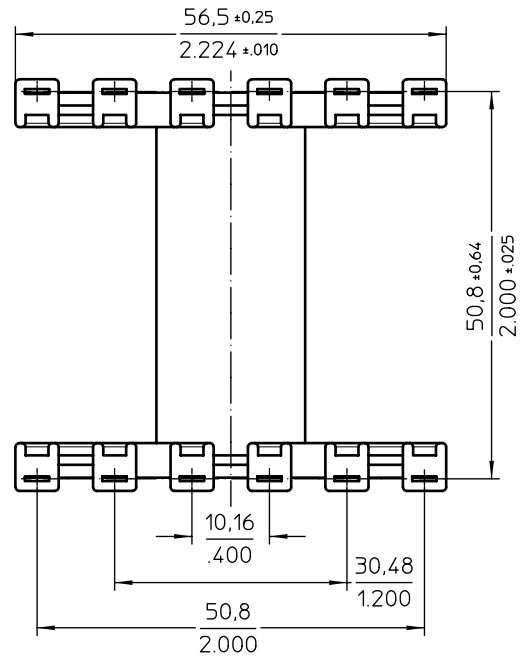
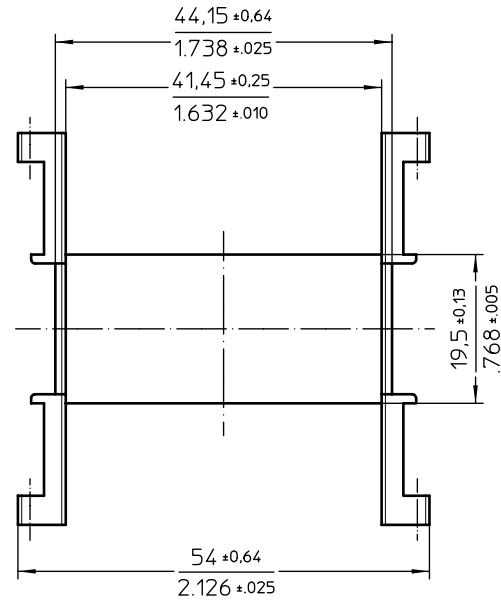
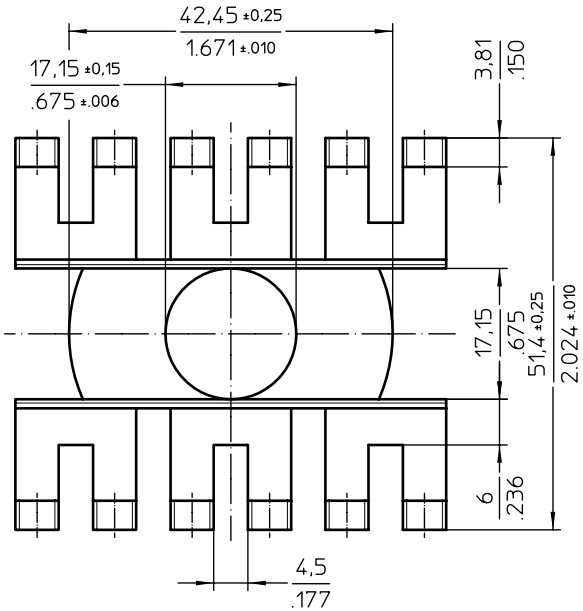

Available pins:
 4322 021 03741 PIN/H-EC
 4322 021 03751 PIN-EC

Coil former material: Technyl A-20V25 (PA6.6), glass-reinforced.
 UL file number: E44716(M) - UL94V-0.
 Max. operating temp.: acc. to IEC 60 085 class B, 130°C.

CLASSNO.		2001-06-05	
CP-EC70-1S		4322 021 03731	
NAME NAAM	M.Veekens	SUPERS. VERV.	4335 000 27371
MPA	CHECK CONTR.	DAT.	2001-06-05
Property of Eigendom van		STUK BL. nr	112 - 001
© FERROXCUBE 2000		1	A3