

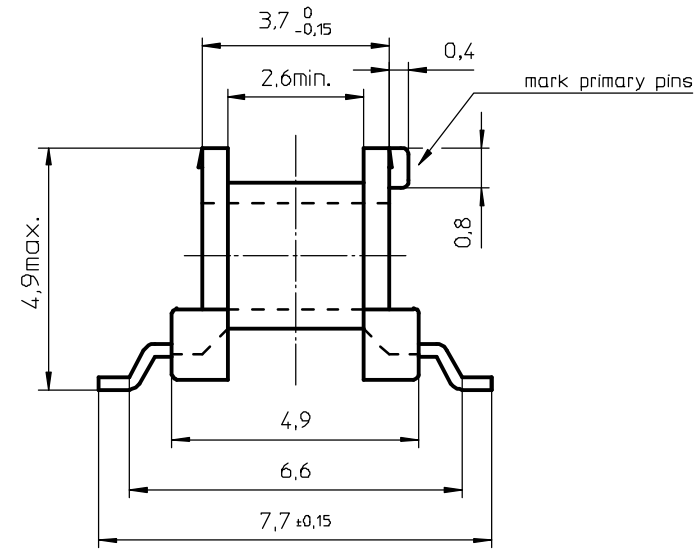

1 2 3 4 5 6 7 8

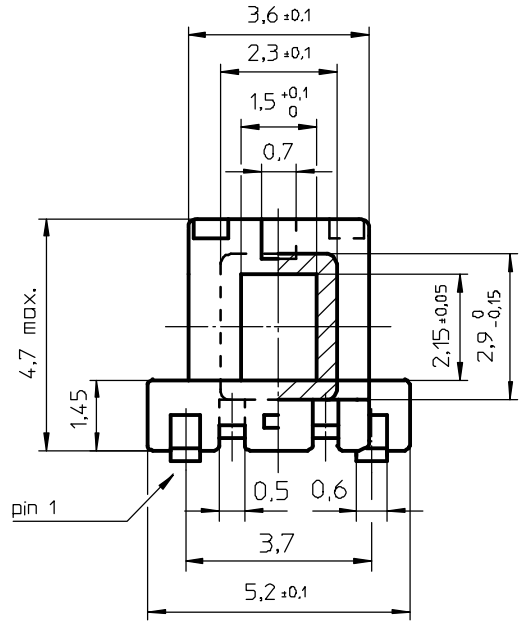

**PROPOSED PAD ARRANGEMENT**

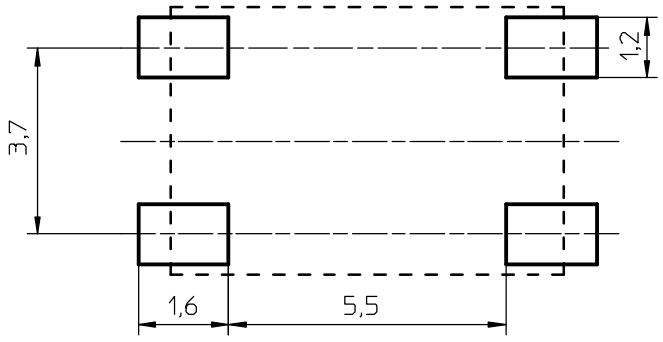

Coil former material: Sumikasuper E4008 (LCP), glass-reinforced.  
 UL file number: E54705 - UL94V-0  
 Pin material: CuSn - Ni flash, Sn plated.  
 Max operating temp: acc. to IEC 60085 class F, 155°C.  
 Resistance to soldering heat: acc. to IEC 60068-2-20 Part 2, Test Tb, method 1B, 350°C - 3,5sec.  
 Solderability: acc. to IEC 60068-2-20 Part 2, Test Ta, method 1, 235°C - 2sec.  
 Min. winding area: 1,5 mm<sup>2</sup>.  
 Mean length of turn: 12,6 mm.

CLASS NO.		CPHS-E5,3/2-1S-4P-Z		4322 021 06001		03-02-20	
NAME	J. Tjon	SUPERS		1	SP	112 - 001	069
MPA	CHECK	DATE	03-02-20	Property of	© FERROXCUBE 2000		
	CONTR.			Eigendom van			

1 2 3 4

a  
b  
c  
d