

FERROXCUBE

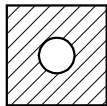

1 2 3 4

*pin: knurled and on 2 sides flattened

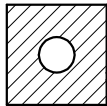
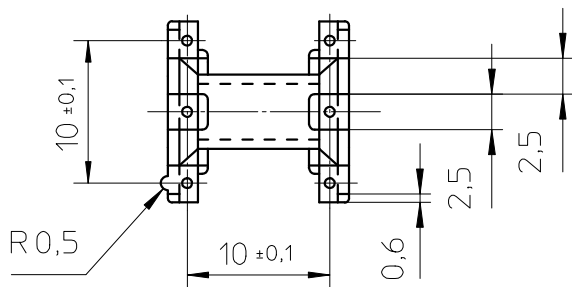
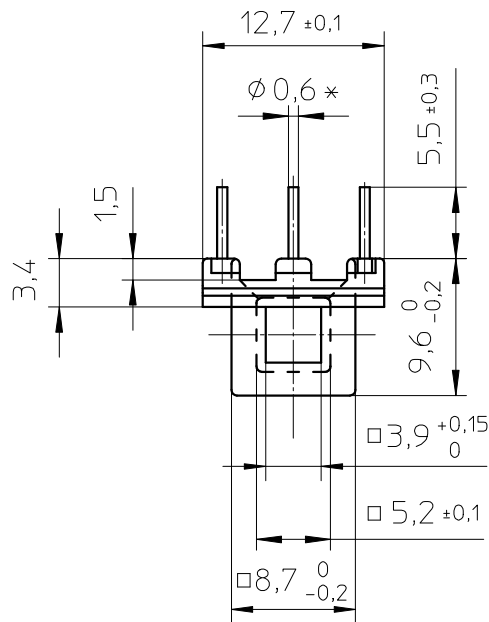
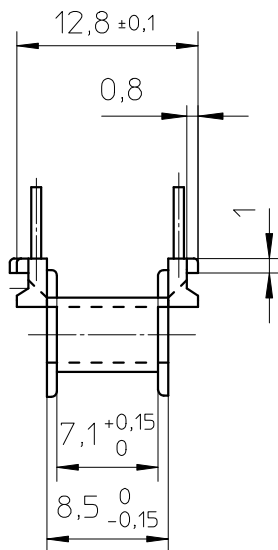

HOLE PATTERN:

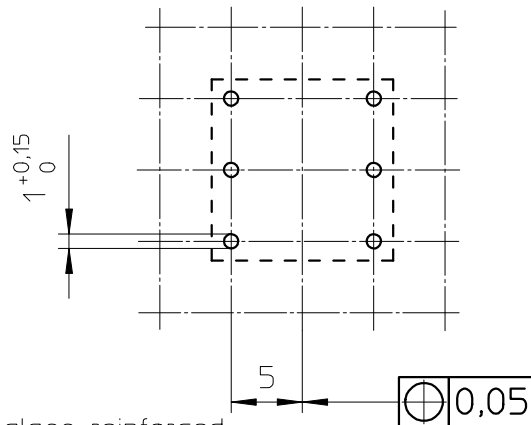

Coil former material : Ultramide A3X2G5 (PA6.6), glass-reinforced

UL file number: E41871 - UL94-V0

Pin material : CuSn6 , Sn plated.

Max. operating temp. : 130°C, class B

Resistance to soldering heat : 350°C - 2sec.

Solderability : IEC 68-2-20 Part 2, Test Ta, method 1.

Winding area : 11,6 mm.²

Mean length of turn : 24 mm.

CLASS.NO.		CPH-E13/7/4-1S-6P		4312 021 26202		91-06-21	
						91-09-13	
						99-10-06	
						02-07-05	
						06-05-08	
NAME NAAM	A.Wojtasz	SUPERS. VERV.	1	SH BL.	112 - 001	010	A4
MPA	CHECK CONTR.	DAT.	91-06-21	Property of Eigendom van		© FERROXCUBE 2000	