

FERROXCUBE

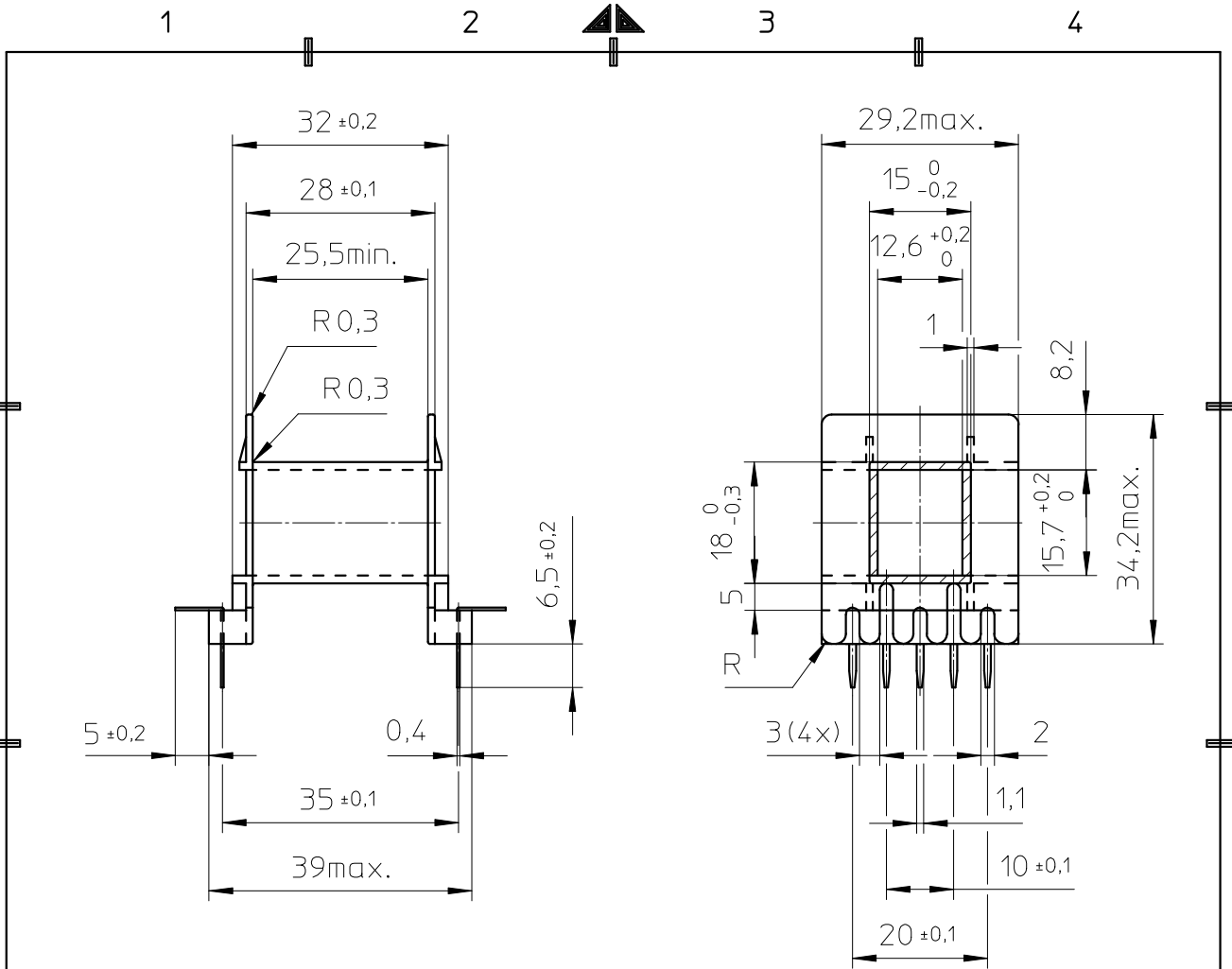

HOLE PATTERN :

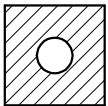
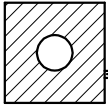
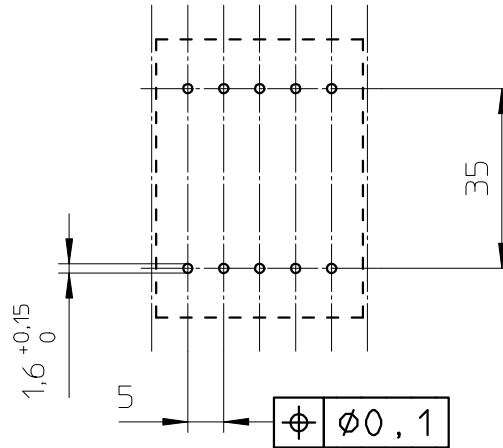

Coil former material: Durethan AKV30H (PA6.6), glass-reinforced.

UL file number: E41613 - UL94-HB.

Pin material: CuSn, Sn plated.

Max. operating temp.: 130°C.

Resistance to soldering heat: 400°C - 2sec.

Solderability: IEC 68-2-20 Part 2, Test Ta, method 1.

Winding area: 178 mm².

Mean length of turn: 93 mm.

CLASS.NO.		CPH-E42/21/15-1S-10P		4322 021 31833		91-11-22			
97-02-14						92-01-24			
						95-08-27			
						99-10-06			
NAME NAAM A.Wojtasz		SUPERS. VERV.	1	SH BL.	112	-	001	010	A4
MPA	CHECK CONTR.	DAT.	91-11-22	Property of Eigendom van	© FERROXCUBE 2000				