

**COIL FORMERS**

**General data for E55/28/21 coil former without pins**

PARAMETER	SPECIFICATION
Coil former material	polyamide (PA6.6), glass reinforced, flame retardant in accordance with "UL 94-HB"; UL file number E41613(M)
Maximum operating temperature	130 C, "IEC 60085", class B

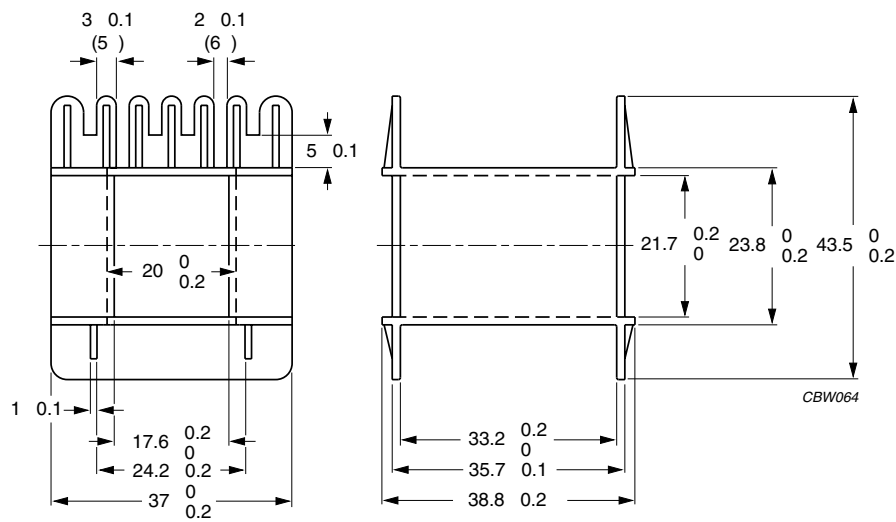

Dimensions in mm.

Fig.2 E55/28/21 coil former (E).

**Winding data for E55/28/21 coil former without pins (E)**

NUMBER OF SECTIONS	MINIMUM WINDING AREA (mm <sup>2</sup> )	MINIMUM WINDING WIDTH (mm)	AVERAGE LENGTH OF TURN (mm)	TYPE NUMBER
1	250	33.2	116	CP-E55/28/21-1S