

Hole Pattern Proposal:

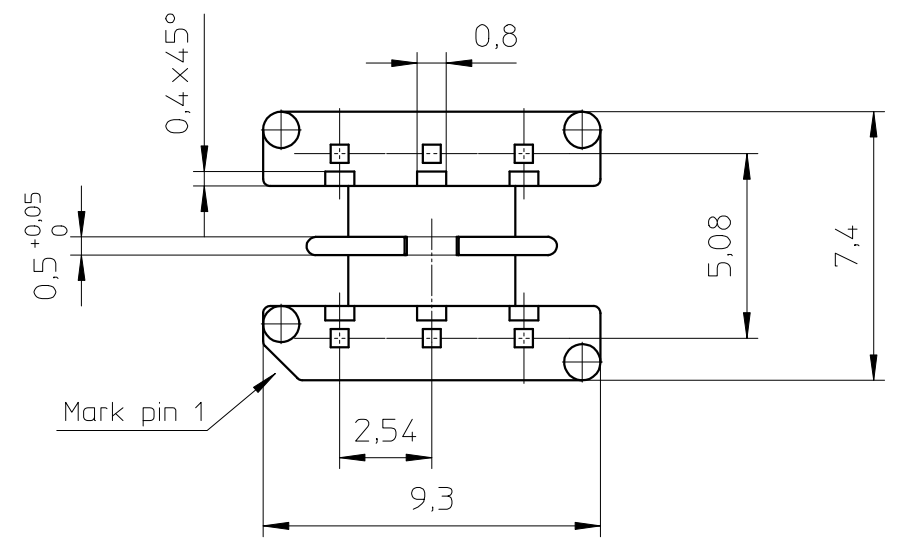

Coil former material: Sumikon PM9630 (PF), glass-reinforced.  
 UL file number: E41429 - UL94V-0.  
 Pin material: Copperclad steel, Sn plated.  
 Max. operating temp.: acc. to IEC 60 085 class H, 180°C.  
 Resistance to soldering heat: acc. to IEC 60 068-2-20 Part 2, Test Tb, method 1B, 350°C-3,5s.  
 Solderability: acc. to IEC 60 068-2-20 Part 2, Test Ta, method 1, 235°C-2s.  
 Min. winding area: 3,5 mm<sup>2</sup>.  
 Mean length of turn: 18 mm.

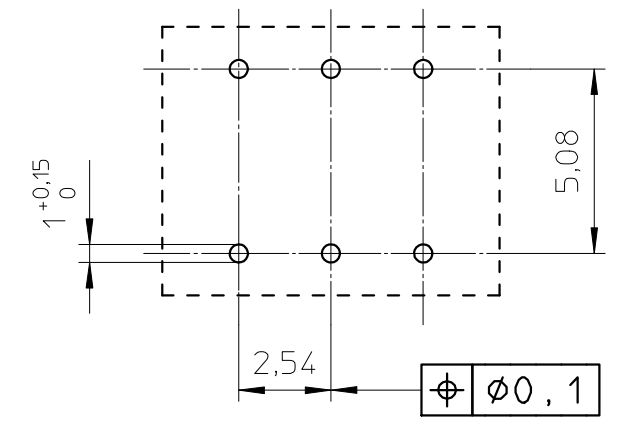
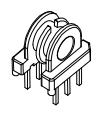

CLASS.NO.		30-08-2006	
NAME NAAM		CSH-EP7-2S-6P-IZ	
CHECK CONTR.		4322 021 06571	
NAME NAAM	A.Wojtasz	SUPERS. VERV.	1 SH SH 112 - 001
MPA	CHECK CONTR.	DAT.	30-08-2006
Property of Eigendom van		© FERROXCUBE 2006	
			A3