

**FERROXCUBE**

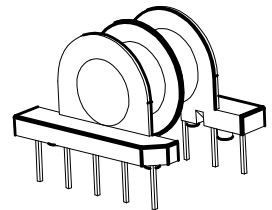
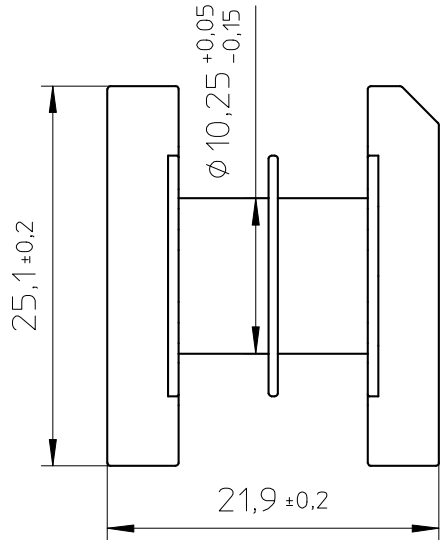
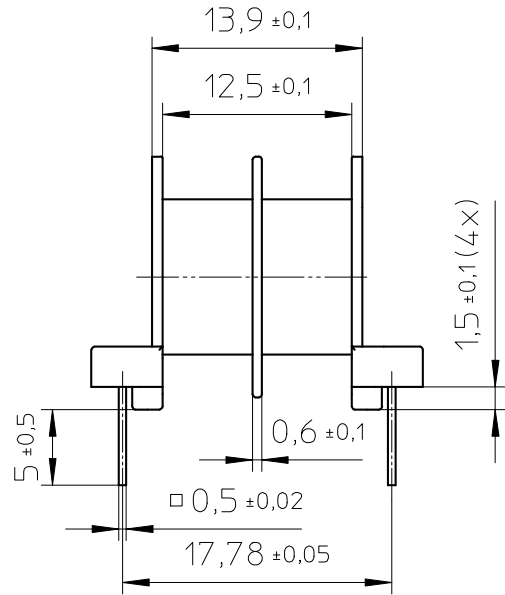
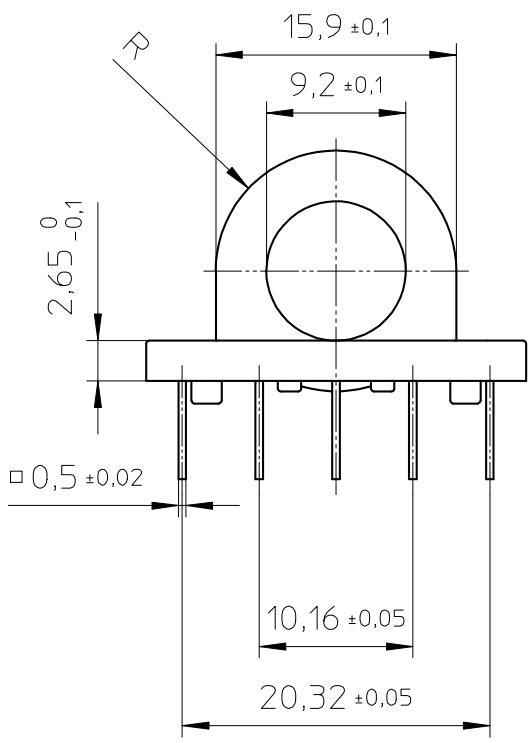

Coil former material: Sumikon PM9820 (PF), glass-reinforced.

UL file number: E41429 - UL94V-0.

Pinmaterial: Copperclad steel, Sn plated.

Max. operating temp: acc to IEC 60 085 class H, 180°C.

Resistance to soldering heat acc. to IEC 60 068-2-20, Part 2, Test Tb, method 1A, 260°C-5s

Solderability acc. to IEC 60 068-2-20, Part 2, Test Ta, method 1, 235°C-2s

Min. winding area: 2×19 mm<sup>2</sup>

Mean length of turn: 39.4 mm.

CLASSNO.

CSH-EP20-2S-10P-T

4322 021 0423

1 2002-06-06

1 2005-03-11

NAME  
NAAM Tjon

SUPERS.  
VERV.

1

SH  
BL.

112

-

001

010

A4

MPA

CHECK  
CONTR.

DAT. 02-06-06

Property of  
Eigendom van

© FERROXCUBE 2000