

FERROXCUBE



c

d



e

f

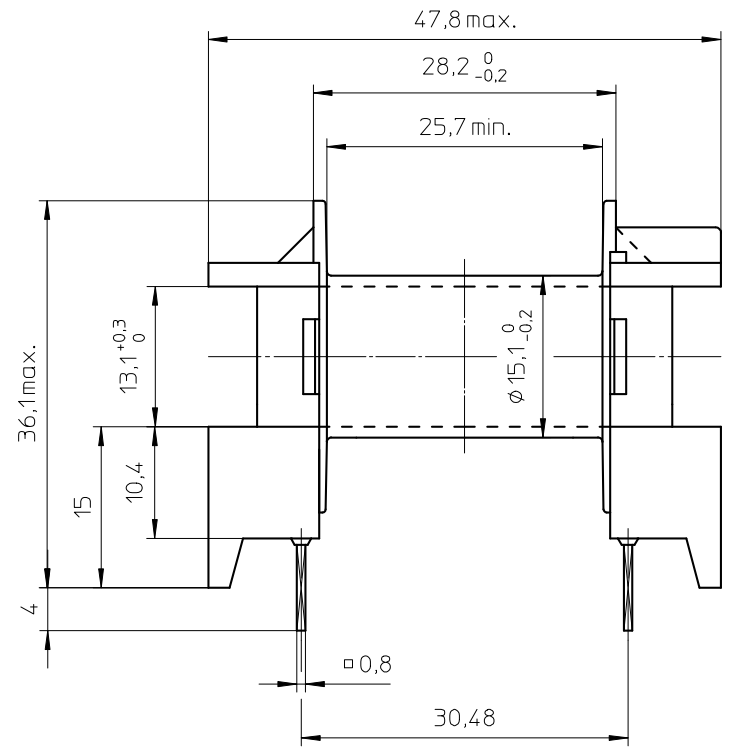
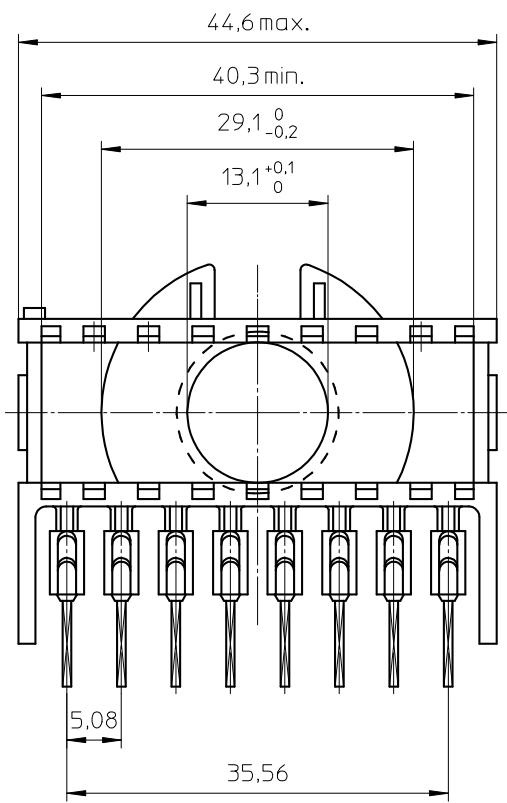

HOLE PATTERN:

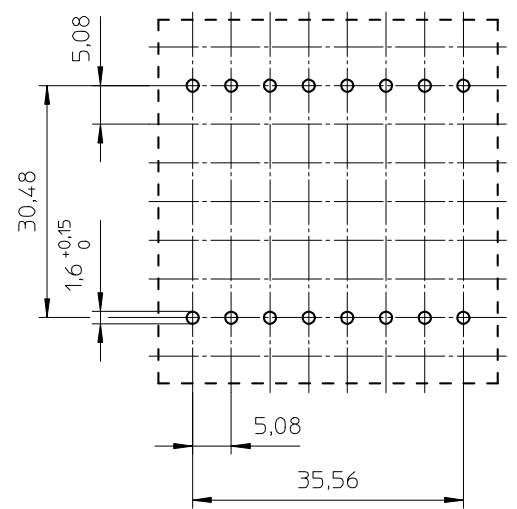

Coil former material: Valox 420SE0 (PBT), glass-reinforced.
UL file number: E45329(R) - UL94V-0.

Pin material: Copper-plated steel wire, Sn plated.
Max. operating temp.: acc. to IEC 60 085 class F, 155°C.

Resistance to soldering heat: acc. to IEC 60 068-2-20 Part 2, Test Tb, method 1B, 350°C - 3,5sec

Solderability: acc. to IEC 60 068-2-20 Part 2, Test Ta, method 1, 235°C - 2sec.

Min. winding area: 177 mm².

Mean length of turn: 69 mm.

CLASSNO.		CPH-ETD39-1S-16P		4322 021 01651		96-02-06
98-01-20						98-01-20
						2004-09-28
						2008-06-19
NAME NAAM	M.Trynqiel	SUPERS. VERV.	001	SPRSH RUBL	112 - 001	069
MPA	CHECK CONTR.	DAT.	96-02-06	Property of Eigenaam van	© FERROXCUBE 2008	
						A3