

FERROXCUBE

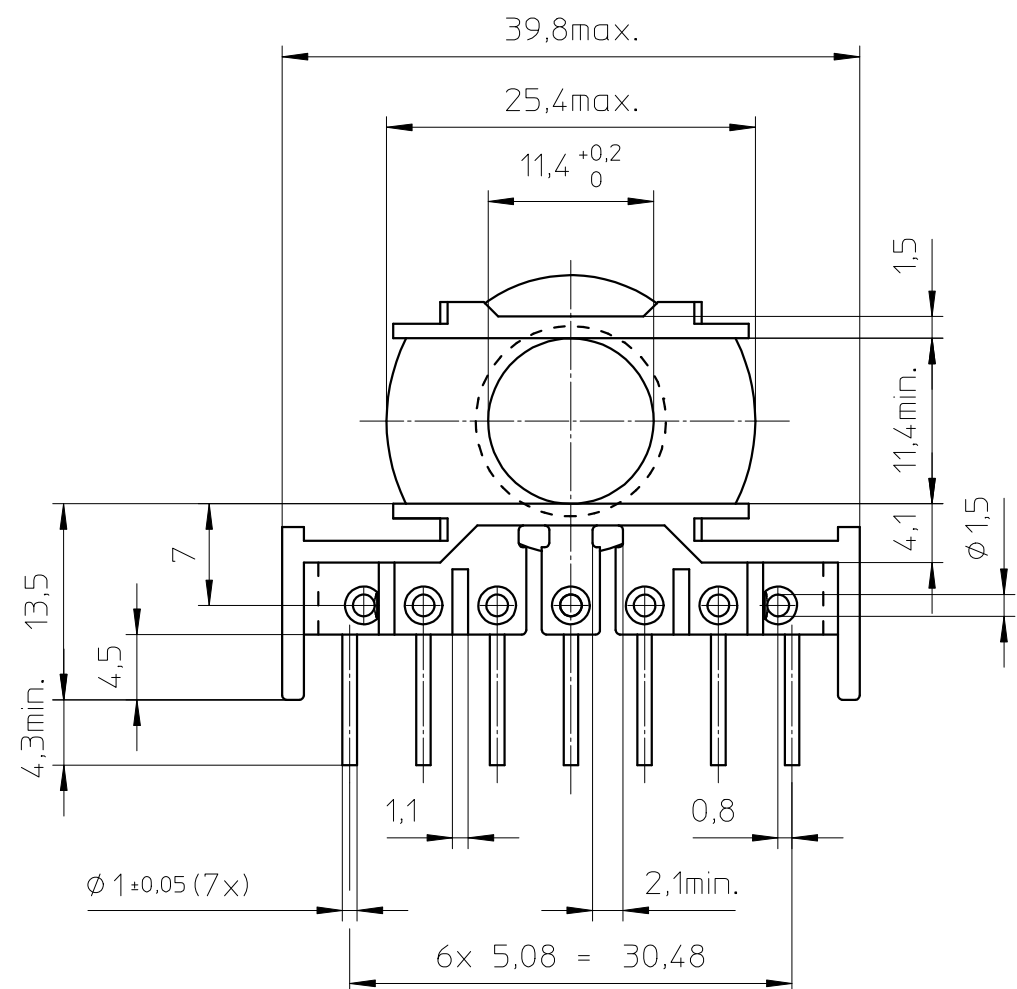
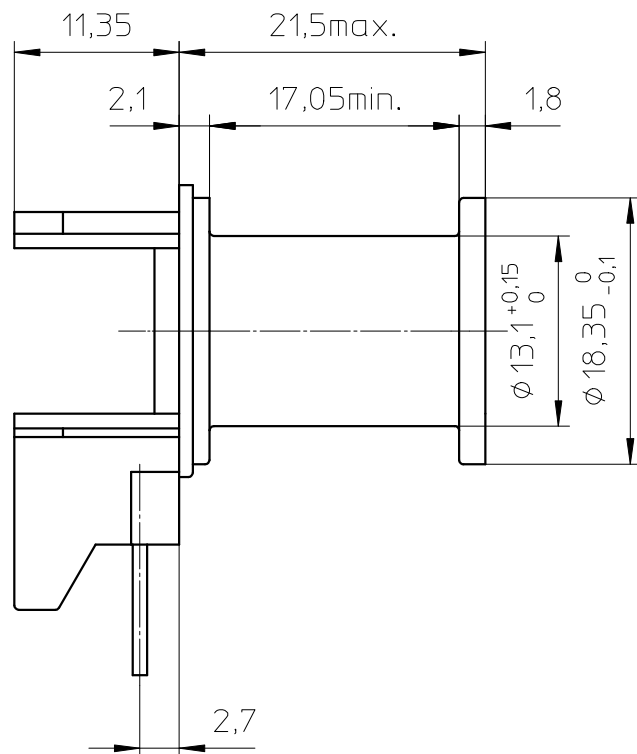

Pin arrangement:

Scale: 1:1
Schaal: 1:1

See also drawing 4322 021 04351

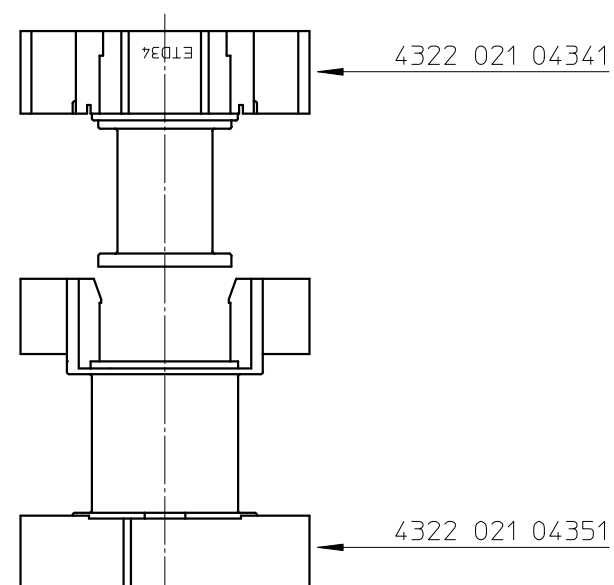
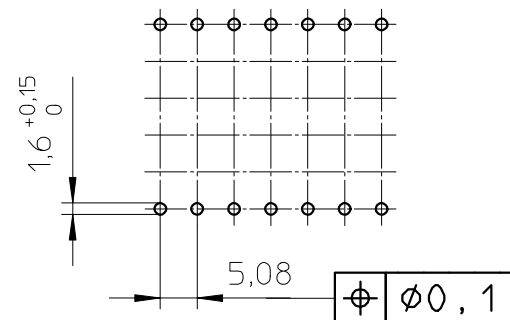

Coil former material: Sumikon PM9630 (PF), glass-reinforced.
 UL file number: E41429 - UL94V-0.
 Pin material: Copperclad steel, Sn plated.
 Max. operating temp.: acc. to IEC 60 085 class H, 180°C.
 Resistance to soldering heat: acc. to IEC 60 068-2-20 Part 2, Test Tb, method 1B, 350°C - 3,5s.
 Solderability: acc. to IEC 60 068-2-20 Part 2, Test Ta, method 1, 235°C - 2s.
 Min. winding area: 42,6 mm²
 Mean length of turn: 49,4 mm.

CLASS.NO.	CSCI-ETD34-1S-7P-T		4322 021 04341	2002-07-11 2005-03-08
NAME NAAM	Tjon	SUPERS. VERV.	1	SH SH BL BL 112 - 001 069
MPA	CHECK CONTR.	DAT.	2002-07-11	Property of Eigendom van © FERROXCUBE 2000