

**FERROXCUBE**

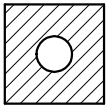
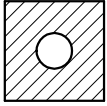

1 2 3 4

a

b

c

d

a

b

c

d

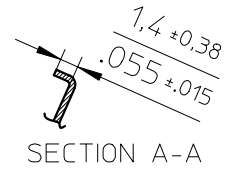
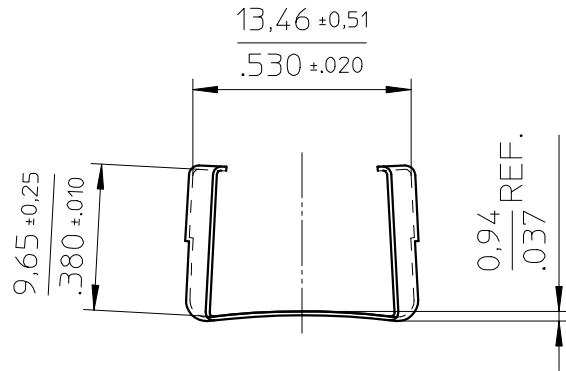
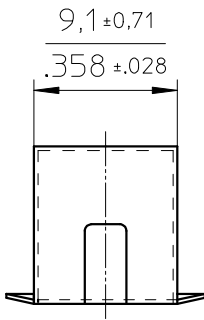
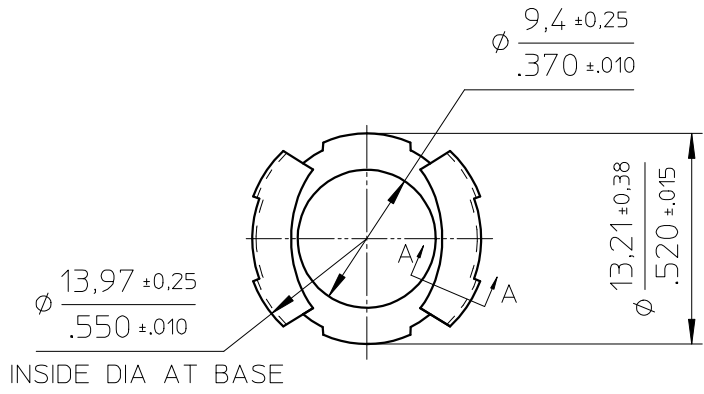

Material: High carbon steel springsteel thickness 0.011 inch (0.28 mm)  
 austemper Hrc 44-51,  
 Ni flash thickness 0.00006-0.00008 inch (1,5 - 2,0 μm)  
 Sn electroplated thickness 0.00015-0.00020 inch (4 - 5 μm)

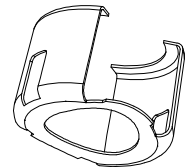

CLASS.NO.		CLM/T-P14/8		4335 000 26491		01-06-01
						06-08-25
NAME NAAM	A.Wojtasz	SUPERS. VERV.		SH BL.	-	A4
MPA	CHECK CONTR.	DAT.	01-06-01	Property of Eigendom van	© FERROXCUBE 2000	