

FERROXCUBE

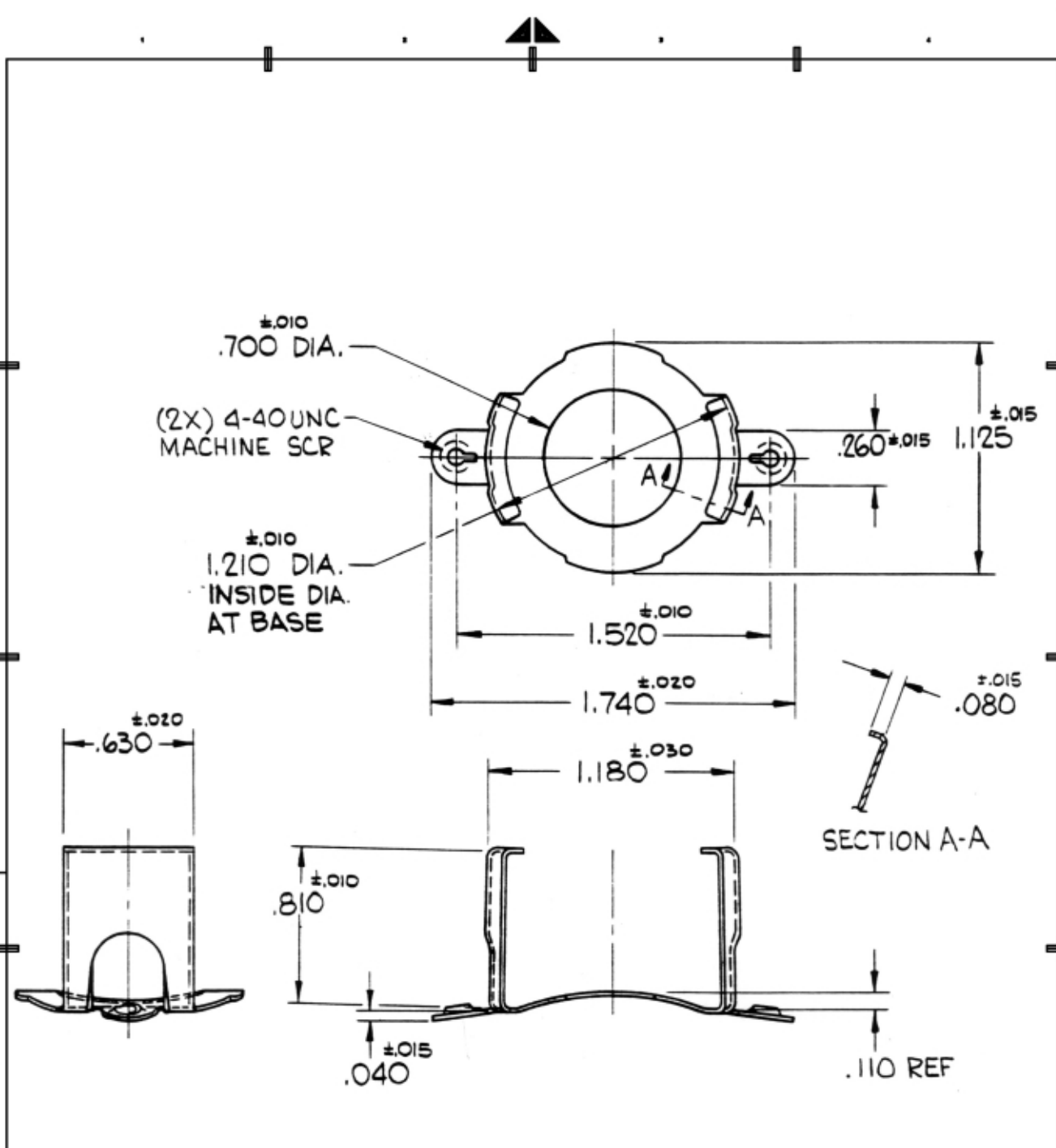
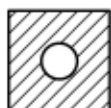
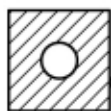

Material: High carbon steel 0.017 thk
heat treat Hrc 42-44, Sn electroplated 0.00015 min

				01-06-01	
		CLM/TS-P30/19		4335 000 26341	