

**F**

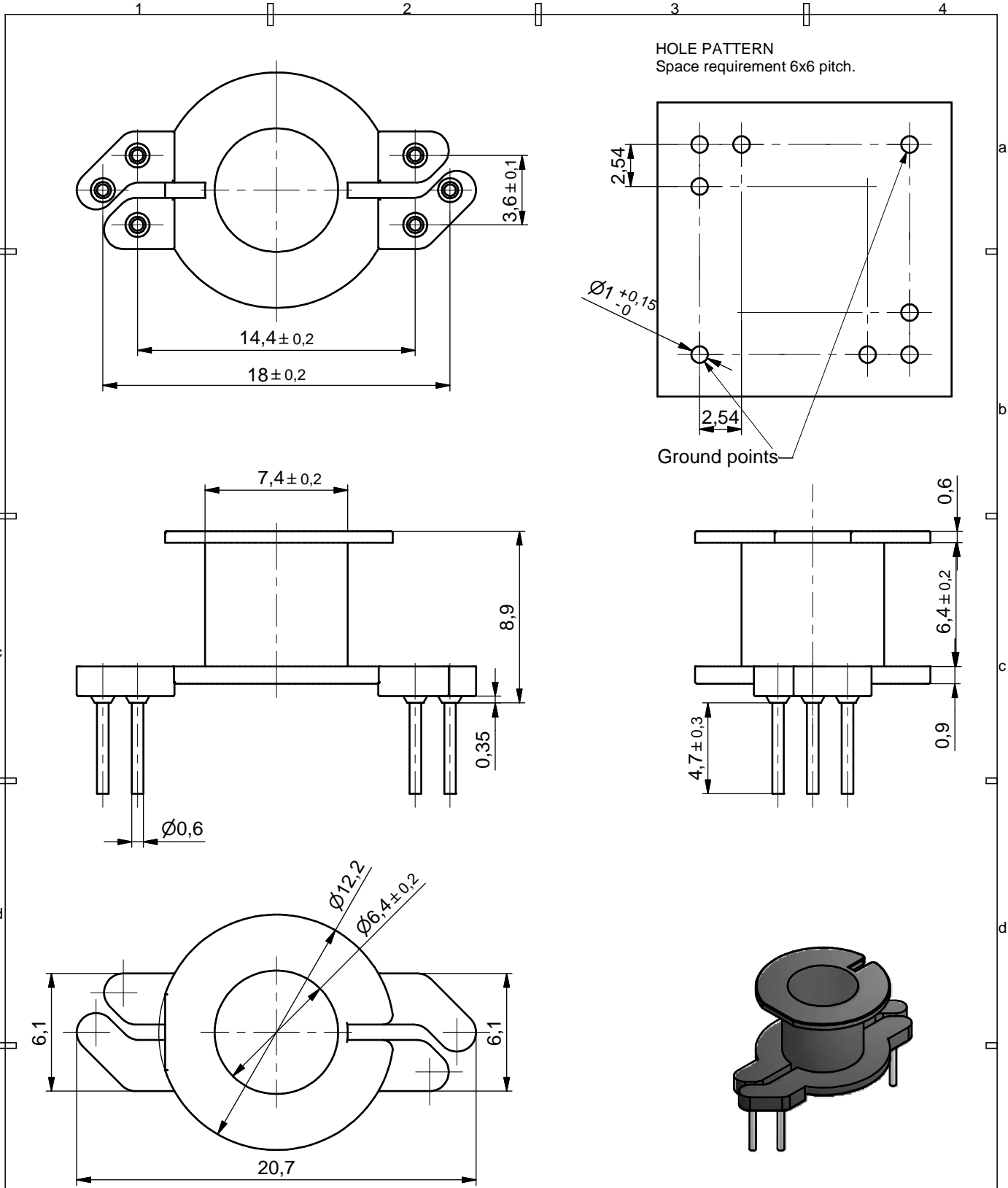

Coil former material : Sumikon PM9630 (PF), glass-reinforced  
 UL file number: E41429 - UL94V-0

Pin material: CP wire , Sn plated  
 Max. operating temp.: acc. to IEC 60 085 class H, 180°C  
 Resistance to soldering heat: acc. to IEC 60 068-2-20 Part 2, Test Tb, method 1B, 350°C - 3,5 se c.  
 Solderability : acc. to IEC 60 068-2-20 Part2, Test Ta, method 1, 235°C - 2 sec.  
 Min. widening area : 15 sq mm.  
 Mean length of turn: 30 mm.

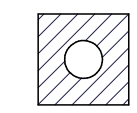
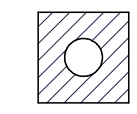
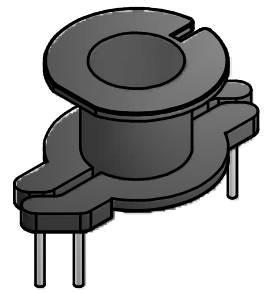

CLASS.NO.					5
					4
					3
					2
					1
					2009-12-01
NAME M. Tryngiel	SUPERS.	001	SH BL	SH BL	112 - 001
	DATE:	Property of	FERROXCUBE Polska Sp. z o.o.		010
					A4

CSV-RM6R-1S-6P-IZ-C

**4322 021 07211**