

FERROXCUBE

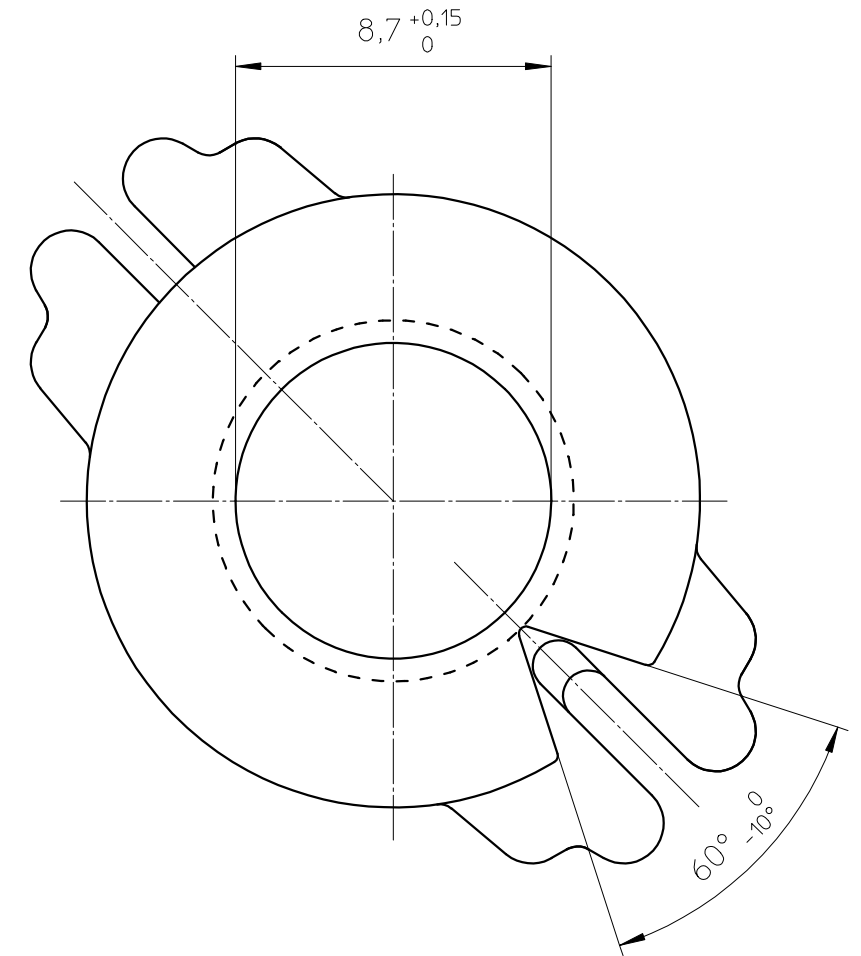

HOLE PATTERN:

Space requirement 8x8 pitch.

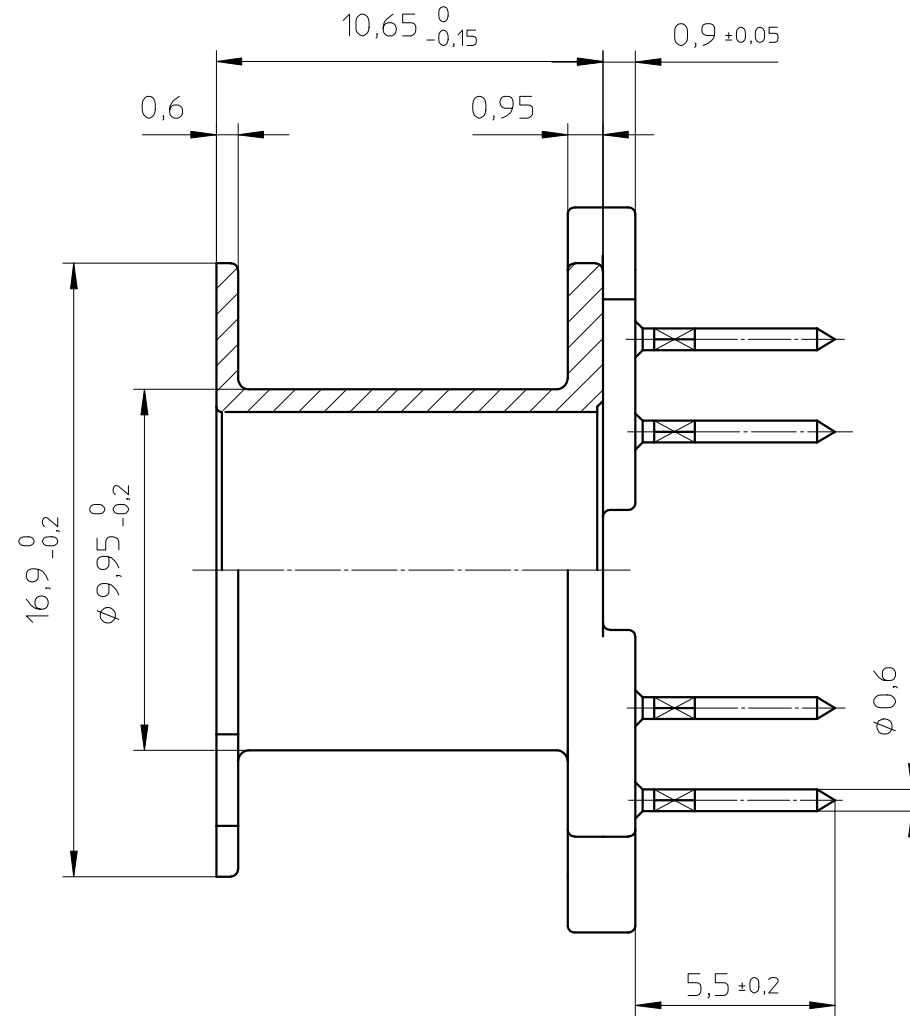
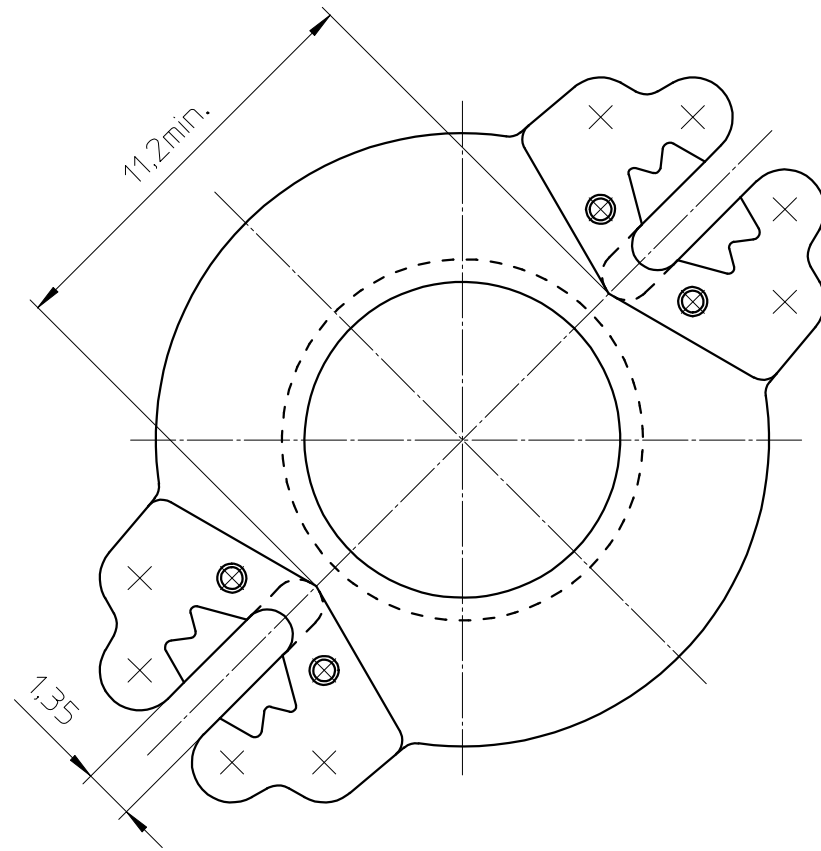
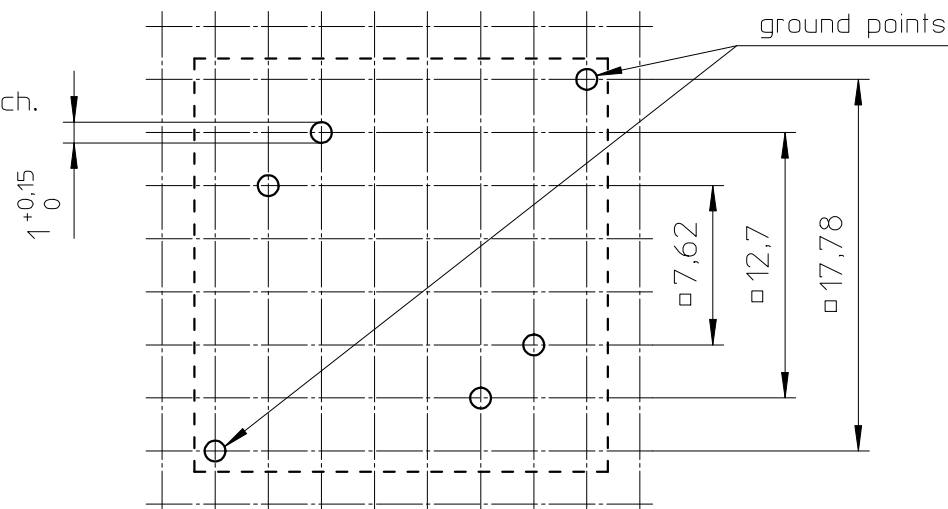

Coil former material: Bakelite UP 3420 (UP), glass-reinforced.
 UL file number: E61040 - UL94V-0.
 Pin material: CuSn - Ni flash, Sn plated.
 Max. operating temp.: acc. to IEC 60 085 class F, 155°C.
 Resistance to soldering heat: acc. to IEC 60 068-2-20 Part 2, Test Tb, method 1B, 350°C - 3,5sec
 Solderability: acc. to IEC 60 068-2-20 Part 2, Test Ta, method 1, 235°C - 2sec.
 Min. winding area: 30 mm².
 Mean length of turn: 42 mm.

CLASS.NO.	89-12-15		112 - 001		010	04-09-28
	CSV-RM8-1S-4P		4322 021 34861			2005-09-01
						97-04-18
						00-05-02
						00-08-01
NAME NAAM	M.Veekens	SUPERS. VERV.	1	SH BL	112 - 001	010
MPA	CHECK CONTR.	DAT.	89-03-15	Property of Eigendom van	© FERROXCUBE 2000	
						A3