

FERROXCUBE

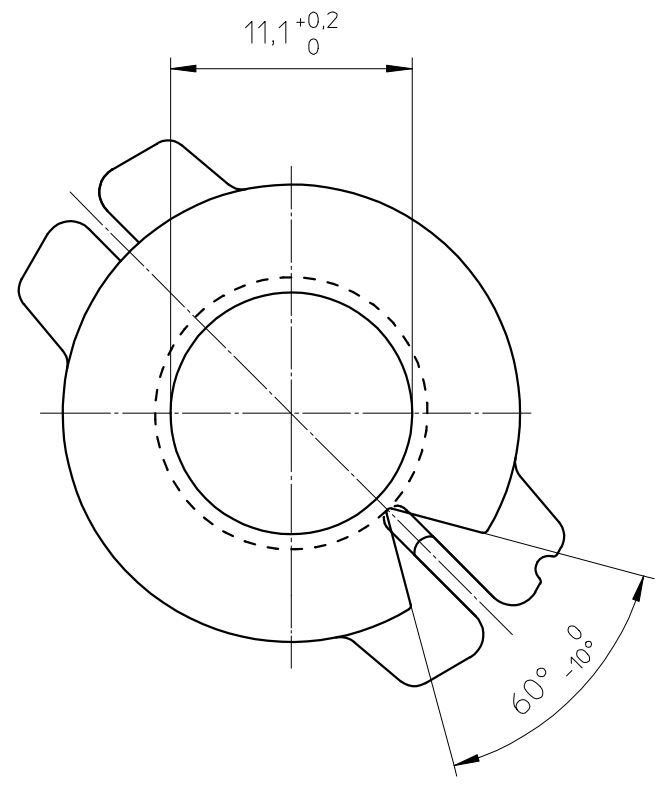

HOLE PATTERN:
Space requirement 10x10 pitch

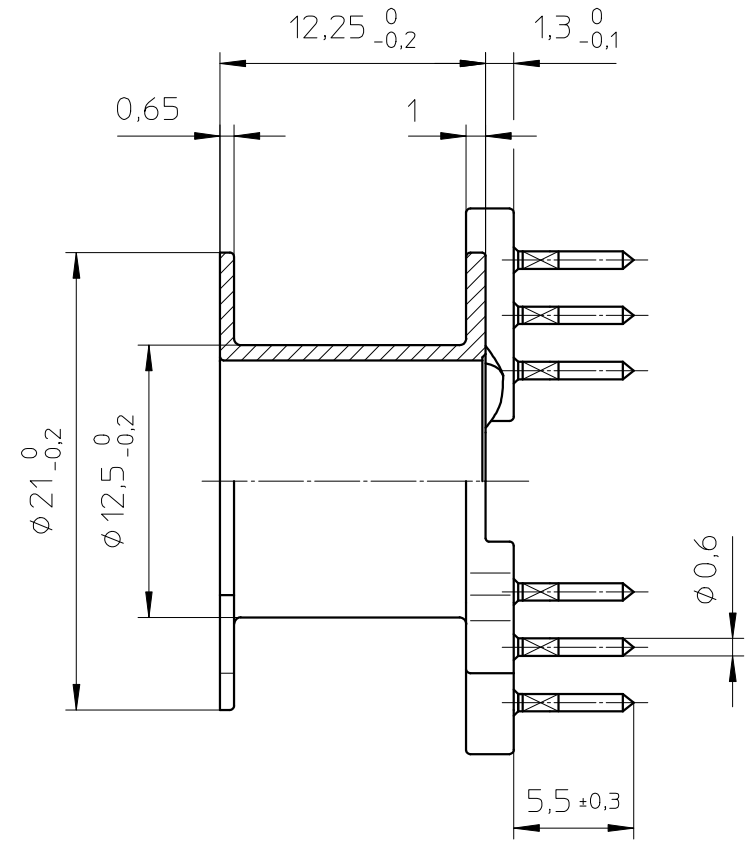
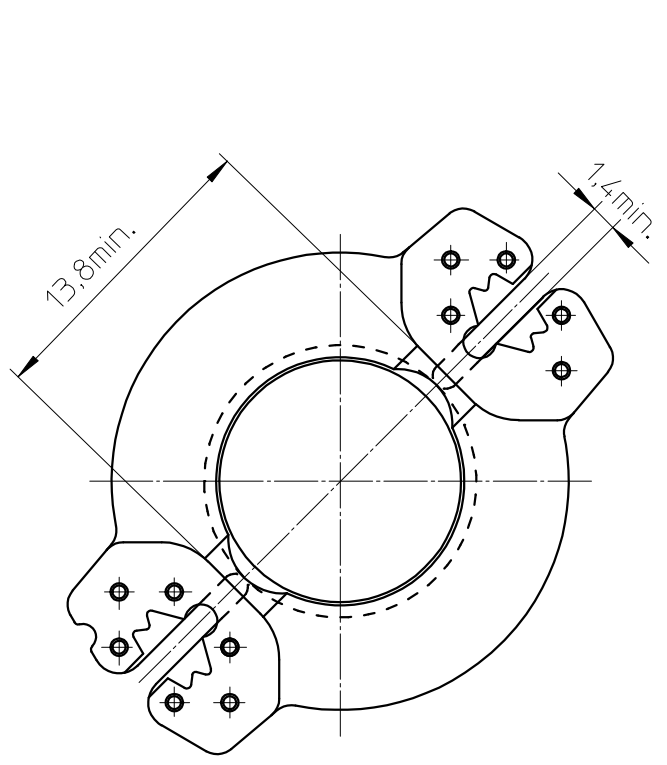
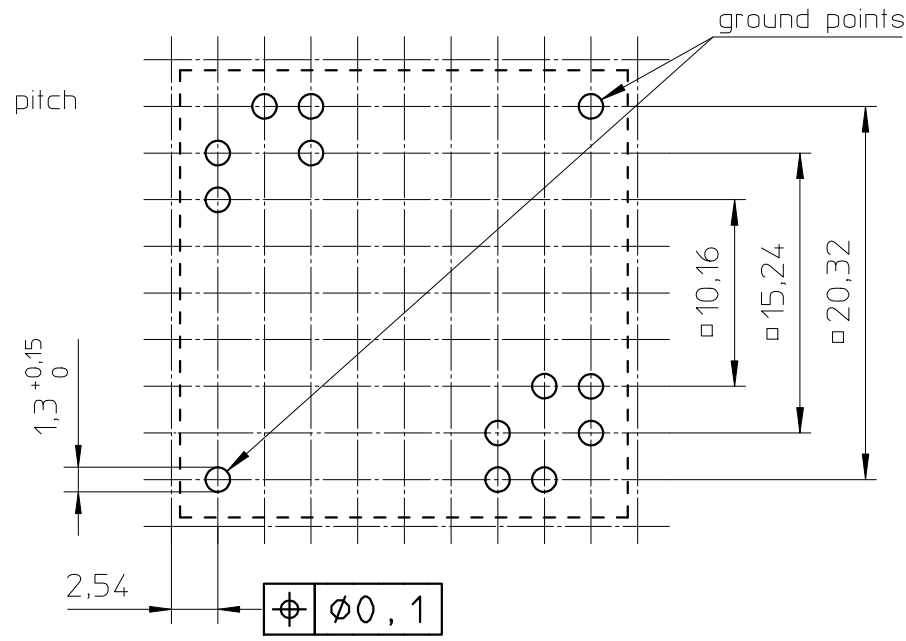

Coil former material: Bakelite UP 3420, glass-reinforced
 UL file number: E61040 - UL94V-0.
 Pin material: CuSn - Ni flash, Sn plated.
 Max. operating temp.: acc. to IEC 60 085 class F, 155°C
 Resistance to soldering heat: acc. to IEC 60 068-2-20 Part 2, Test Tb, method 1B, 350°C-3.5sec.
 Solderability: IEC 60 068-2-20 Part 2, Test Ta, method 1, 235°C-2sec.
 Winding area: 42.7 mm.²
 Mean length of turn: 52.3mm.

CLASS.NO.	CSV-RM10-1S-11P		4322 021 34751	97-04-18
00-05-04				2004-09-28
				2005-09-01
NAME NAAM MPA	M.Veekens	SUPERS. VERV.	1 SH SH BL BL 112 - 001	010
CHECK CONTR.	DAT. 89-04-05	Property of Eigendom van	© FERROXCUBE 2000	
				A3