

Soft Ferrites

ETD cores and accessories

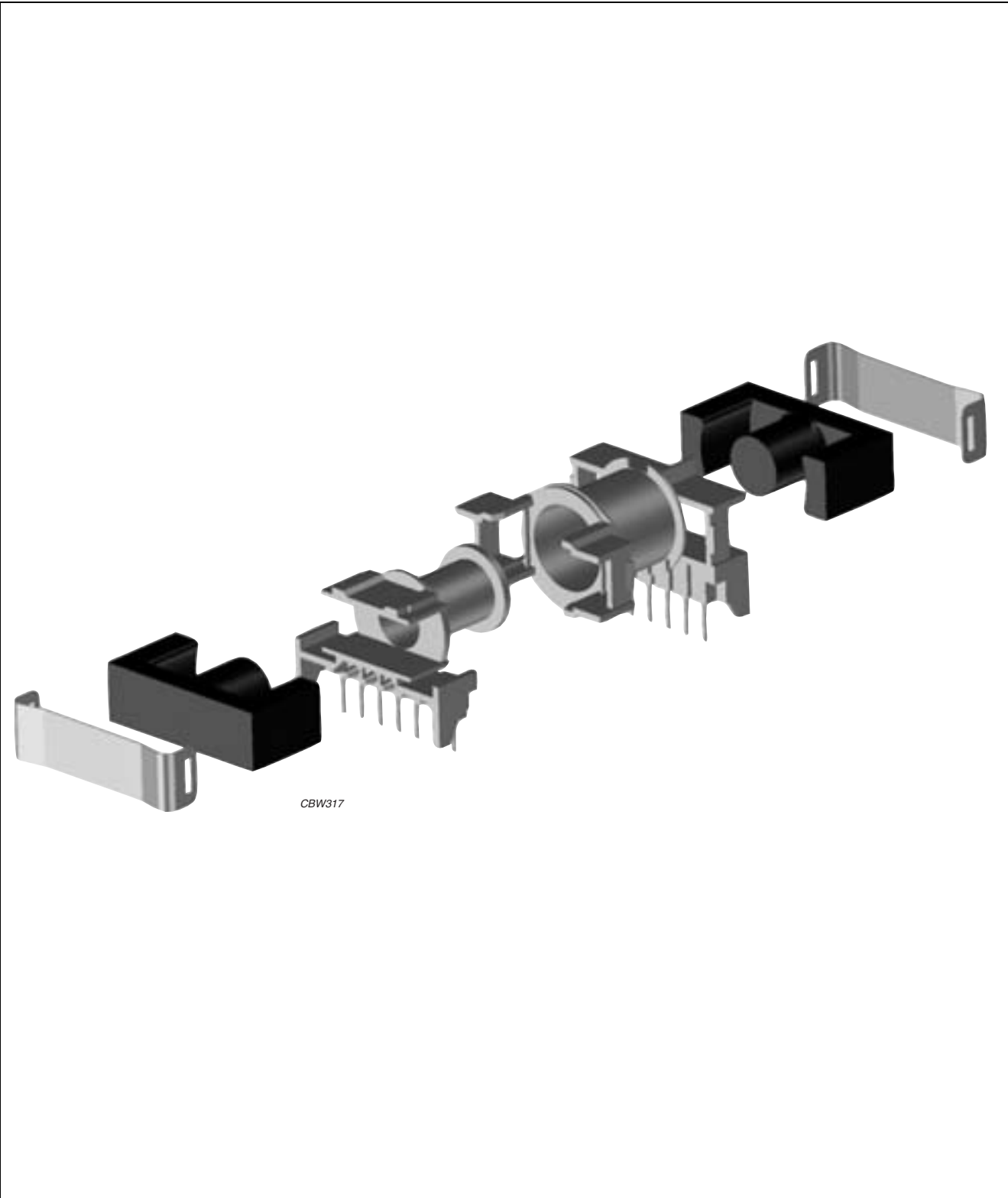

Soft Ferrites

ETD cores and accessories

PRODUCT OVERVIEW AND TYPE NUMBER STRUCTURE

Product overview ETD cores

CORE TYPE	V _e (mm ³)	A _e (mm ²)	MASS (g)
ETD29/16/10	5470	76.0	14
ETD34/17/11	7640	97.1	20
ETD39/20/13	11500	125	30
ETD44/22/15	17800	173	47
ETD49/25/16	24000	211	62
ETD54/28/19	35500	280	90
ETD59/31/22	51500	368	130

- In accordance with IEC 62317, part 6.

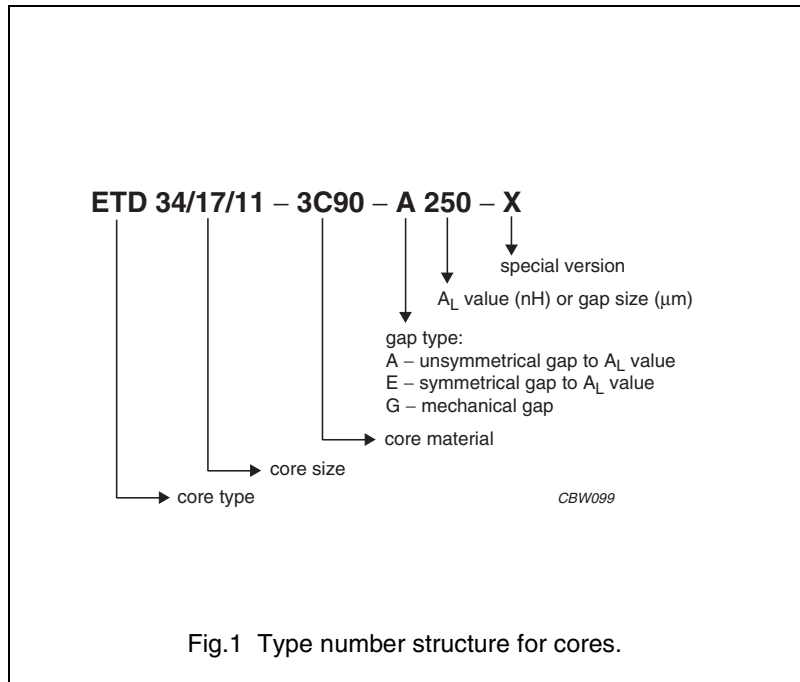

Fig.1 Type number structure for cores.

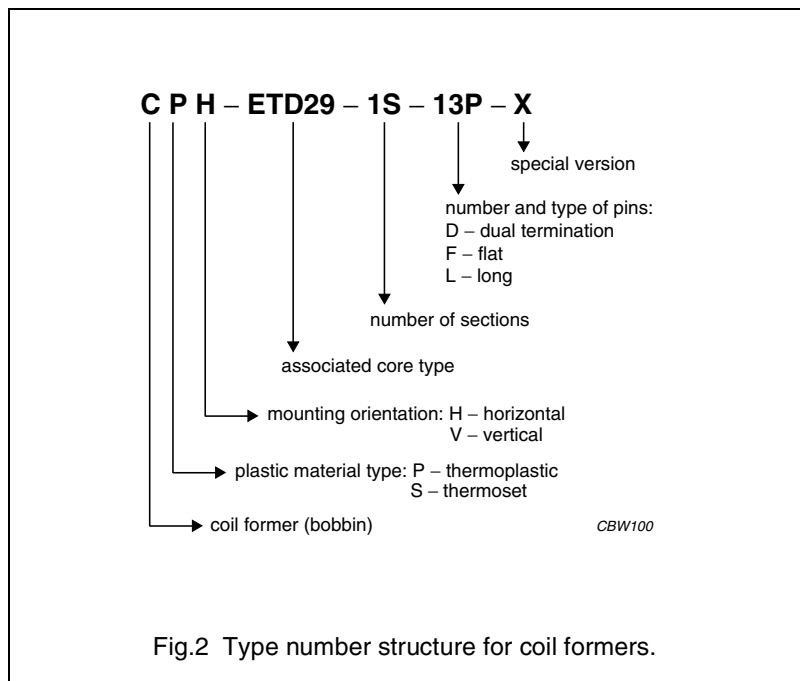

Fig.2 Type number structure for coil formers.