

DATA SHEET

P14/8

P cores and accessories

Supersedes data of September 2004

2008 Sep 01



FERROXCUBE
A YAGEO COMPANY

CORE SETS

Effective core parameters

SYMBOL	PARAMETER	VALUE	UNIT
$\Sigma(l/A)$	core factor (C1)	0.789	mm ⁻¹
V_e	effective volume	495	mm ³
l_e	effective length	19.8	mm
A_e	effective area	25.1	mm ²
A_{min}	minimum area	19.8	mm ²
m	mass of set	≈ 3.2	g

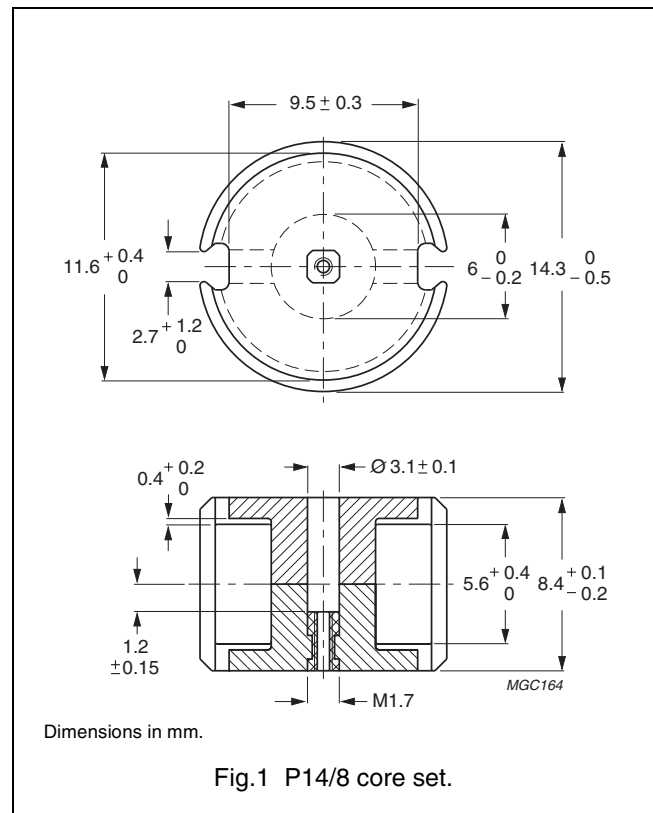

Core sets for filter applications

Clamping force for A_L measurements, 60 ±20 N.

GRADE	A_L (nH)	μ_e	TOTAL AIR GAP (μ m)	TYPE NUMBER (WITH NUT)	TYPE NUMBER (WITHOUT NUT)
3D3 ^{sup}	40 ± 3%	≈ 25	≈ 1170	P14/8-3D3-E40/N	P14/8-3D3-E40
	63 ± 3%	≈ 40	≈ 650	P14/8-3D3-E63/N	P14/8-3D3-E63
	100 ± 3%	≈ 63	≈ 360	P14/8-3D3-E100/N	P14/8-3D3-E100
	1000 ± 25%	≈ 630	≈ 0	—	P14/8-3D3
3H3 ^{sup}	160 ± 3%	≈ 100	≈ 220	P14/8-3H3-A160/N	P14/8-3H3-A160
	250 ± 3%	≈ 157	≈ 130	P14/8-3H3-A250/N	P14/8-3H3-A250
	315 ± 3%	≈ 198	≈ 100	P14/8-3H3-A315/N	P14/8-3H3-A315
	400 ± 3%	≈ 251	≈ 75	P14/8-3H3-A400/N	P14/8-3H3-A400
	2150 ± 25%	≈ 1350	≈ 0	—	P14/8-3H3

Core sets for general purpose transformers and power applicationsClamping force for A_L measurements, 60 ± 20 N.

GRADE	A_L (nH)	μ_e	AIR GAP (μm)	TYPE NUMBER
3C81	$63 \pm 3\%$	≈ 40	≈ 680	P14/8-3C81-E63
	$100 \pm 3\%$	≈ 63	≈ 390	P14/8-3C81-A100
	$160 \pm 3\%$	≈ 100	≈ 220	P14/8-3C81-A160
	$250 \pm 3\%$	≈ 157	≈ 130	P14/8-3C81-A250
	$315 \pm 3\%$	≈ 198	≈ 100	P14/8-3C81-A315
	$2800 \pm 25\%$	≈ 1760	≈ 0	P14/8-3C81
3C91 <small>des</small>	$2800 \pm 25\%$	≈ 1760	≈ 0	P14/8-3C91
3F3	$63 \pm 3\%$	≈ 40	≈ 680	P14/8-3F3-E63
	$100 \pm 3\%$	≈ 63	≈ 390	P14/8-3F3-A100
	$160 \pm 3\%$	≈ 100	≈ 220	P14/8-3F3-A160
	$250 \pm 3\%$	≈ 157	≈ 130	P14/8-3F3-A250
	$315 \pm 3\%$	≈ 198	≈ 100	P14/8-3F3-A315
	$2000 \pm 25\%$	≈ 1260	≈ 0	P14/8-3F3

Core sets of high permeability gradesClamping force for A_L measurements, 60 ± 20 N.

GRADE	A_L (nH)	μ_e	AIR GAP (μm)	TYPE NUMBER
3E27	$5750 \pm 25\%$	≈ 3610	≈ 0	P14/8-3E27

Properties of core sets under power conditions

GRADE	B (mT) at	CORE LOSS (W) at			
	H = 250 A/m; f = 25 kHz; T = 100 °C	f = 25 kHz; B = 200 mT; T = 100 °C	f = 100 kHz; B = 100 mT; T = 100 °C	f = 100 kHz; B = 200 mT; T = 100 °C	f = 400 kHz; B = 50 mT; T = 100 °C
3C81	≥ 320	≤ 0.1	–	–	–
3C91	≥ 315	–	$\leq 0.03^{(1)}$	$\leq 0.22^{(1)}$	–
3F3	≥ 315	–	≤ 0.06	–	≤ 0.1

Note

1. Measured at 60 °C.

INDUCTANCE ADJUSTERS

General data

PARAMETER	SPECIFICATION
Material of head and thread	polypropylene (PP), glass fibre reinforced
Maximum operating temperature	125 °C

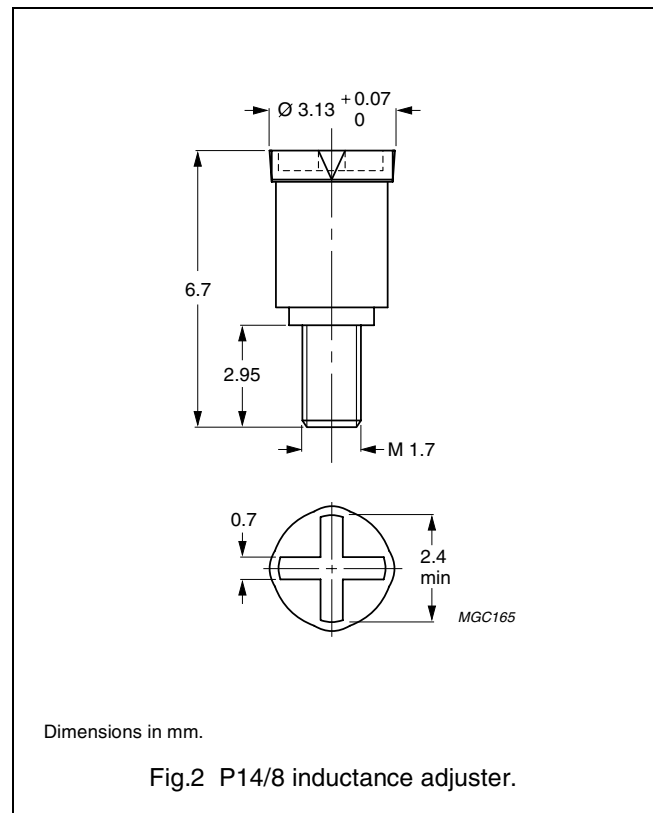

Inductance adjuster selection chart ^{sup up} (applies to all types)

GRADE	A _L (nH)	TYPES FOR LOW ADJUSTMENT	ΔL/L ⁽¹⁾	TYPES FOR MEDIUM ADJUSTMENT	ΔL/L ⁽¹⁾	TYPES FOR HIGH ADJUSTMENT	ΔL/L ⁽¹⁾
3H3	100	–	–	ADJ-P14-ORANGE	14	–	–
	160	–	–	ADJ-P14-WHITE	17	ADJ-P14-BROWN	24
	250	ADJ-P14-WHITE	10	ADJ-P14-BROWN	15	–	–
	315	ADJ-P14-WHITE	8	–	–	–	–
	400	ADJ-P14-BROWN	9	–	–	–	–
	630	ADJ-P14-BROWN	4	–	–	–	–
3D3	40	–	–	–	–	ADJ-P14-ORANGE	24
	63	–	–	–	–	ADJ-P14-ORANGE	20
	100	ADJ-P14-ORANGE	11	–	–	–	–

Note

1. Maximum adjustment range.

COIL FORMERS

General data for CP-P14/8 coil former

PARAMETER	SPECIFICATION
Coil former material	polybutyleneterephthalate (PBT), glass reinforced, flame retardant in accordance with "UL 94V-0"; UL file number E45329 (R)
Maximum operating temperature	155 °C, "IEC 60085", class F

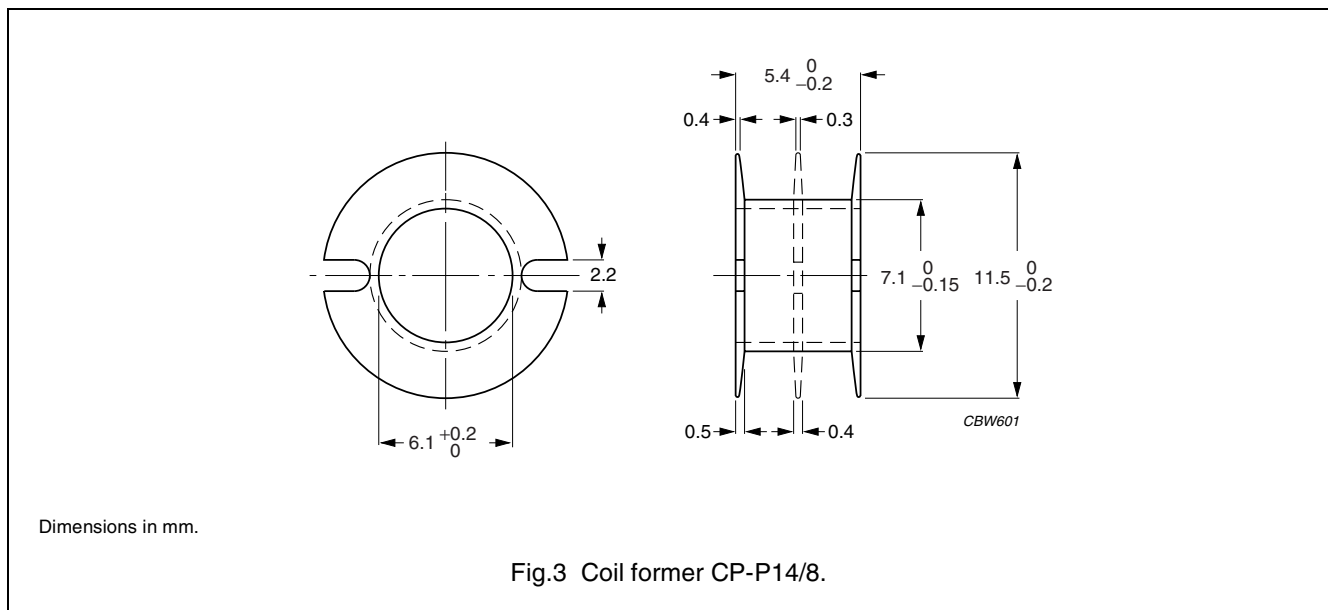

Winding data and area product for CP-P14/8 coil former

NUMBER OF SECTIONS	WINDING AREA (mm ²)	MINIMUM WINDING WIDTH (mm)	AVERAGE LENGTH OF TURN (mm)	AREA PRODUCT Ae x Aw (mm ⁴)	TYPE NUMBER
1	8.8	4.1	28.9	221	CP-P14/8-1S
2	2 x 4.0	2 x 1.85	28.9	2 x 100	CP-P14/8-2S

General data for CP-P14/8-A coil former

PARAMETER	SPECIFICATION
Coil former material	acetal (POM), glass reinforced, flame retardant in accordance with "UL 94-HB"; UL file number E66288(R)
Maximum operating temperature	155 °C, "IEC 60085", class F

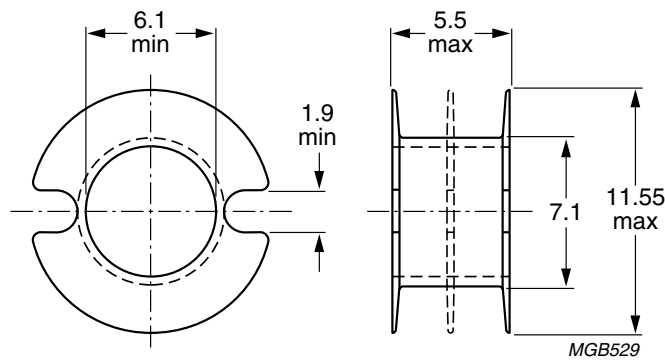

Dimensions in mm.

Fig.4 Coil former CP-P14/8-A.

Winding data and area product for CP-P14/8-A coil former

NUMBER OF SECTIONS	MINIMUM WINDING AREA (mm ²)	NOMINAL WINDING WIDTH (mm)	AVERAGE LENGTH OF TURN (mm)	AREA PRODUCT Ae x Aw (mm ⁴)	TYPE NUMBER
1	9.4	4.5	29.0	236	CP-P14/8-1S-A
2	2 x 4.32	2 x 2.0	29.0	2 x 108	CP-P14/8-2S-A
3	3 x 2.19	3 x 1.2	29.0	3 x 55.0	CP-P14/8-3S-A

General data 4-pins P14/8 coil former for PCB mounting

PARAMETER	SPECIFICATION
Coil former material	polyamide (PA6.6), glass reinforced, flame retardant in accordance with "UL 94V-0"; UL file number E41938(M)
Maximum operating temperature	130 °C, "IEC 60085", class B
Pin material	copper-zinc alloy (CuZn), tin (Sn) plated
Resistance to soldering heat	"IEC 60068-2-20", Part 2, Test Tb, method 1B, 350 °C, 3.5 s
Solderability	"IEC 60068-2-20", Part 2, Test Ta, method 1, 235 °C, 2 s

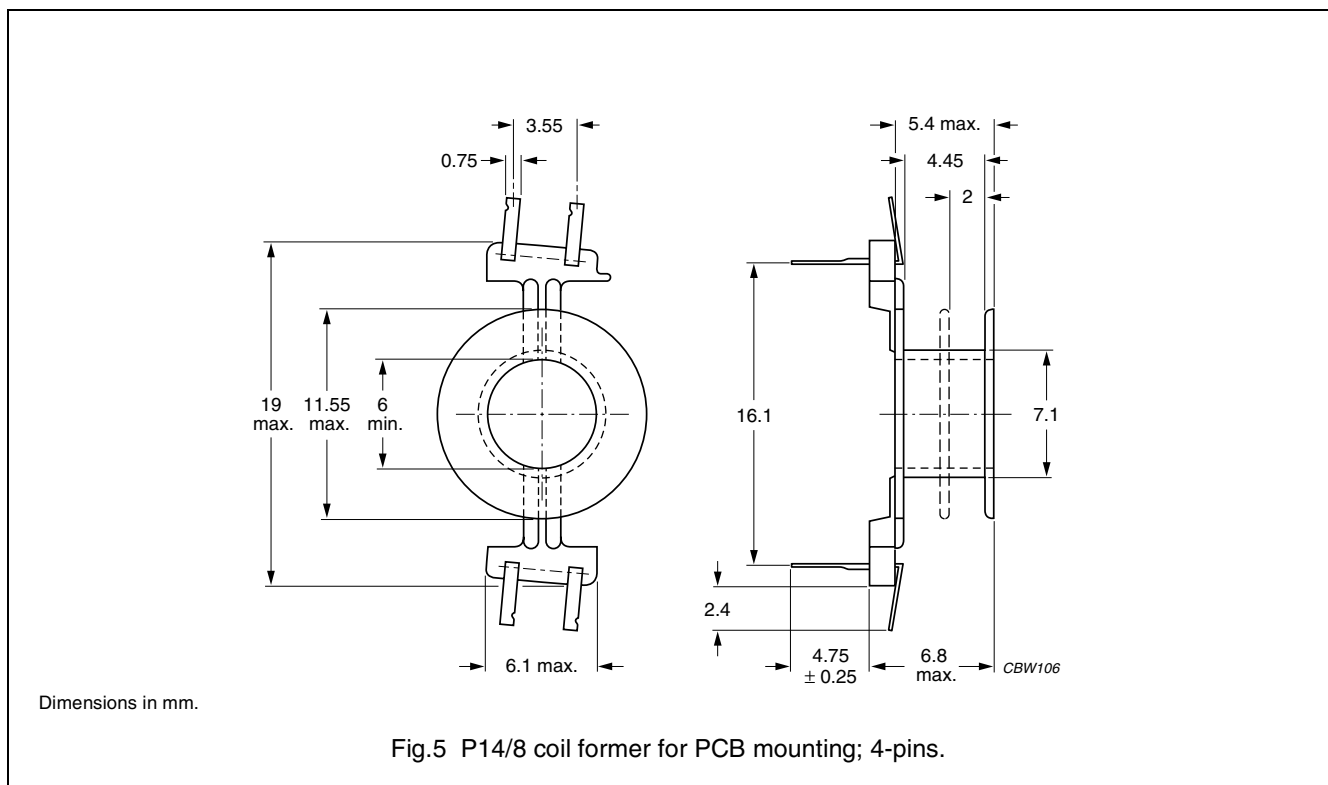

Winding data and area product for 4-pins P14/8 coil former for PCB mounting

NUMBER OF SECTIONS	MINIMUM WINDING AREA (mm ²)	NOMINAL WINDING WIDTH (mm)	AVERAGE LENGTH OF TURN (mm)	LENGTH OF PINS (mm)	AREA PRODUCT Ae x Aw (mm ⁴)	TYPE NUMBER
1	8.65	4.4	29.0	4.75	217	CPV-P14/8-1S-4SPD
1	8.65	4.4	29.0	6.8	217	CPV-P14/8-1S-4SPDL
2	2 x 3.87	2 x 2.0	29.0	4.75	2 x 97.1	CPV-P14/8-2S-4SPD
2	2 x 3.87	2 x 2.0	29.0	6.8	2 x 97.1	CPV-P14/8-2S-4SPDL

General data 6-pins P14/8 coil former for PCB mounting

PARAMETER	SPECIFICATION
Coil former material	polyamide (PA6.6), glass reinforced, flame retardant in accordance with "UL 94V-0"; UL file number E41938(M)
Maximum operating temperature	130 °C, "IEC 60085", class B
Pin material	copper-zinc alloy (CuZn), tin (Sn) plated
Resistance to soldering heat	"IEC 60068-2-20", Part 2, Test Tb, method 1B, 350 °C, 3.5 s
Solderability	"IEC 60068-2-20", Part 2, Test Ta, method 1, 235 °C, 2 s

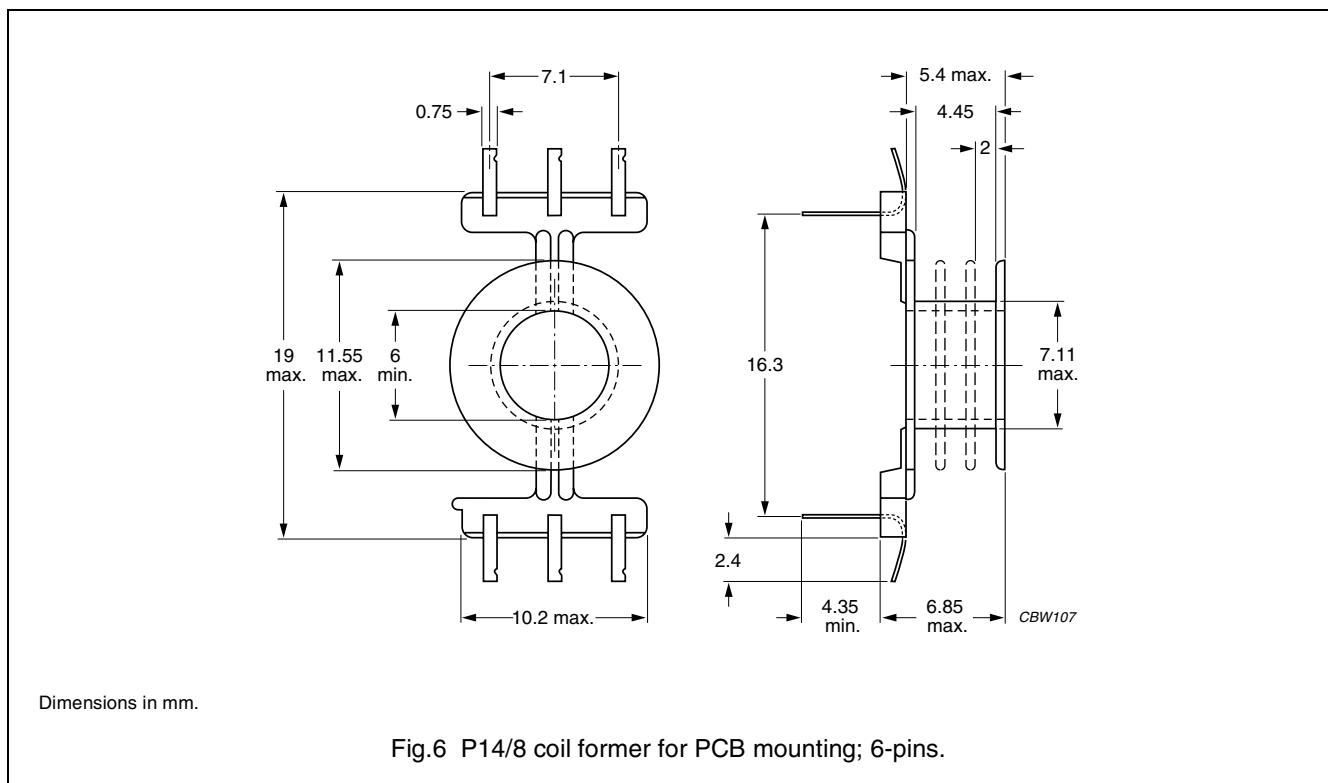

Winding data and area product for 6-pins P14/8 coil former for PCB mounting

NUMBER OF SECTIONS	MINIMUM WINDING AREA (mm ²)	NOMINAL WINDING WIDTH (mm)	AVERAGE LENGTH OF TURN (mm)	LENGTH OF PINS (mm)	AREA PRODUCT Ae x Aw (mm ⁴)	TYPE NUMBER
1	8.65	4.4	29.0	4.4	217	CPV-P14/8-1S-6PD
1	8.65	4.4	29.0	6.8	217	CPV-P14/8-1S-6PDL
2	2 x 3.87	2 x 2.0	29.0	4.4	2 x 97.1	CPV-P14/8-2S-6PD
2	2 x 3.87	2 x 2.0	29.0	6.8	2 x 97.1	CPV-P14/8-2S-6PDL

MOUNTING PARTS

General data for mounting parts

ITEM	REMARKS	FIGURE	TYPE NUMBER
Tag plate	material: phenolformaldehyde (PF), glass reinforced	7	TGP-P14/8-C
	flame retardant: in accordance with "UL 94V-0"; UL file number E41429		
	maximum operating temperature: 180 °C, "IEC 60085", class H		
	pins: copper-tin alloy (CuSn), tin (Sn) plated		
	resistance to soldering heat in accordance with "IEC 60068-2-20", Part 2, Test Tb, method 1B: 350 °C, 3.5 s		
	solderability in accordance with "IEC 60068-2-20", Part 2, Test Ta, method 1: 235 °C, 2 s		
Container	copper-zinc alloy (CuZn), tin (Sn) plated	8	CON-P14/8
	earth pins: presoldered		
Spring	CrNi-steel	9	SPR-P14/8
	spring force: ≈60 N when mounted		
Clamp	spring steel, tin-plated	10	CLM/TP-P14/8
Washer	phenolformaldehyde (PF)	11	WAS-CLM/TP-P14/8

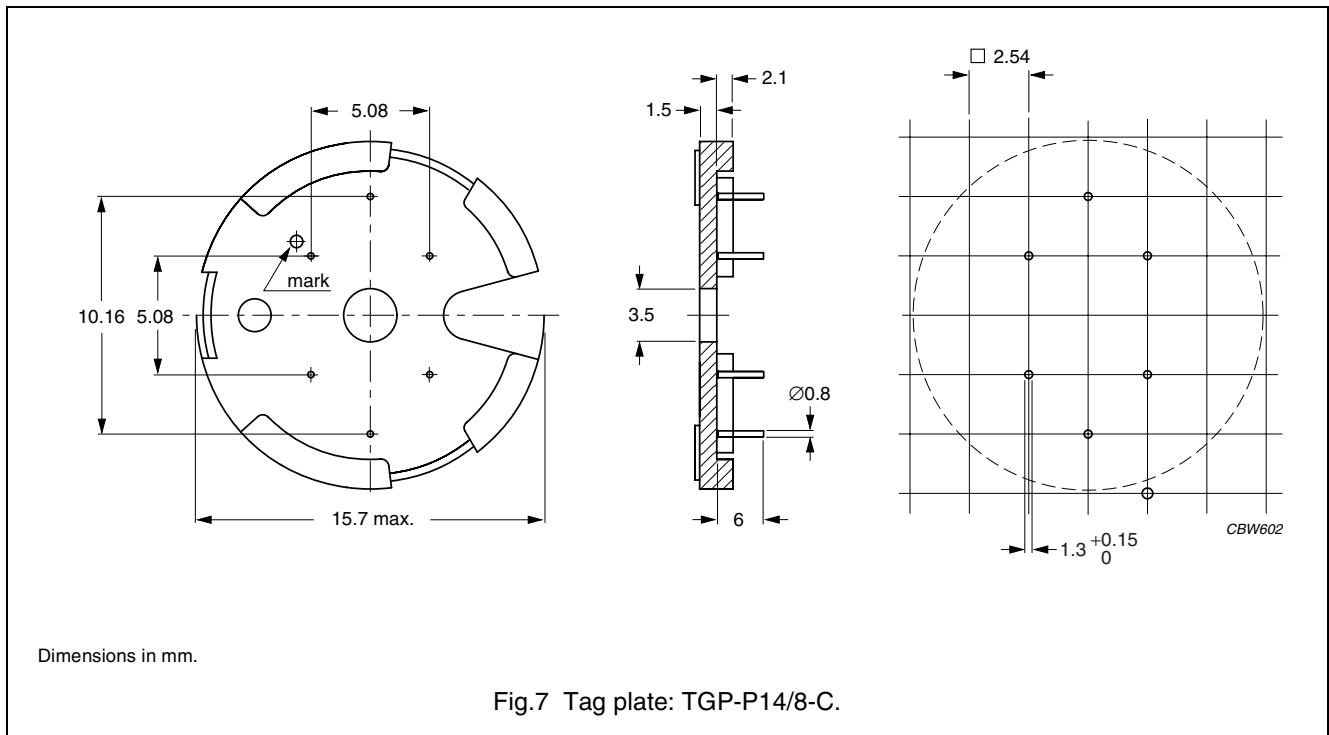

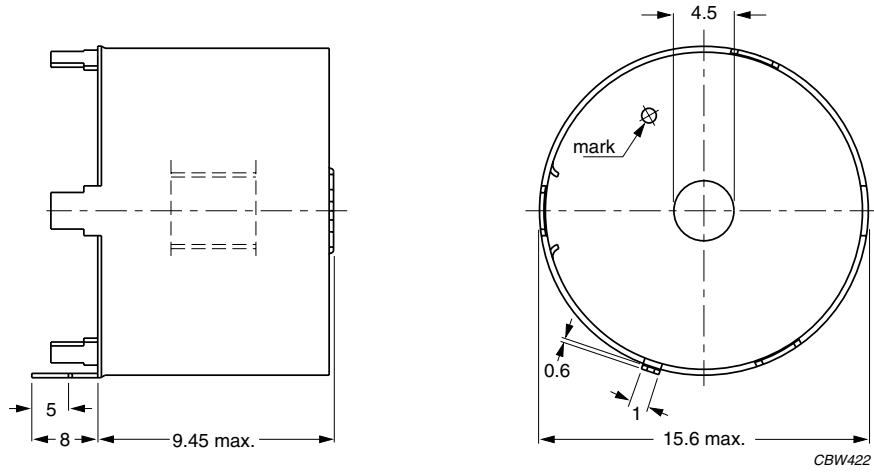

Dimensions in mm.

Fig.8 Container: CON-P14/8.

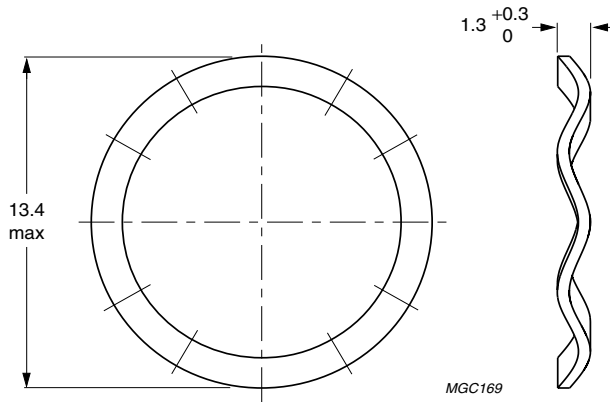

Dimensions in mm.

Fig.9 Spring: SPR-P14/8.

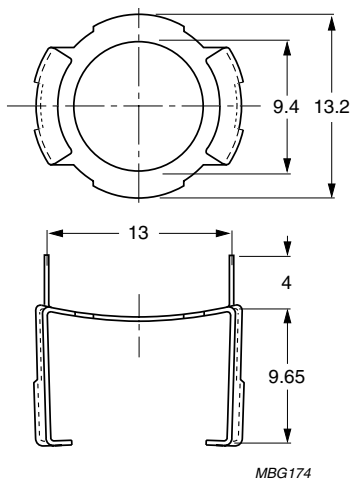

Dimensions in mm.

Fig.10 Clamp: CLM/TP-P14/8.

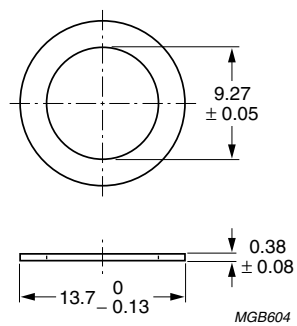

Dimensions in mm.

Fig.11 Washer: WAS-CLM/TP-P14/8.



DATA SHEET STATUS DEFINITIONS

DATA SHEET STATUS	PRODUCT STATUS	DEFINITIONS
Preliminary specification	Development	This data sheet contains preliminary data. Ferroxcube reserves the right to make changes at any time without notice in order to improve design and supply the best possible product.
Product specification	Production	This data sheet contains final specifications. Ferroxcube reserves the right to make changes at any time without notice in order to improve design and supply the best possible product.

DISCLAIMER

Life support applications — These products are not designed for use in life support appliances, devices, or systems where malfunction of these products can reasonably be expected to result in personal injury. Ferroxcube customers using or selling these products for use in such applications do so at their own risk and agree to fully indemnify Ferroxcube for any damages resulting from such application.

PRODUCT STATUS DEFINITIONS

STATUS	INDICATION	DEFINITION
Prototype		These are products that have been made as development samples for the purposes of technical evaluation only. The data for these types is provisional and is subject to change.
Design-in		These products are recommended for new designs.
Preferred		These products are recommended for use in current designs and are available via our sales channels.
Support		These products are not recommended for new designs and may not be available through all of our sales channels. Customers are advised to check for availability.