

DATA SHEET

EC70

EC cores and accessories

Supersedes data of September 2004

2008 Sep 01



FERROXCUBE
A YAGEO COMPANY

CORE SETS

Effective core parameters

SYMBOL	PARAMETER	VALUE	UNIT
$\Sigma(l/A)$	core factor (C1)	0.514	mm ⁻¹
V_e	effective volume	40100	mm ³
l_e	effective length	144	mm
A_e	effective area	279	mm ²
A_{min}	minimum area	211	mm ²
m	mass of core half	≈ 127	g

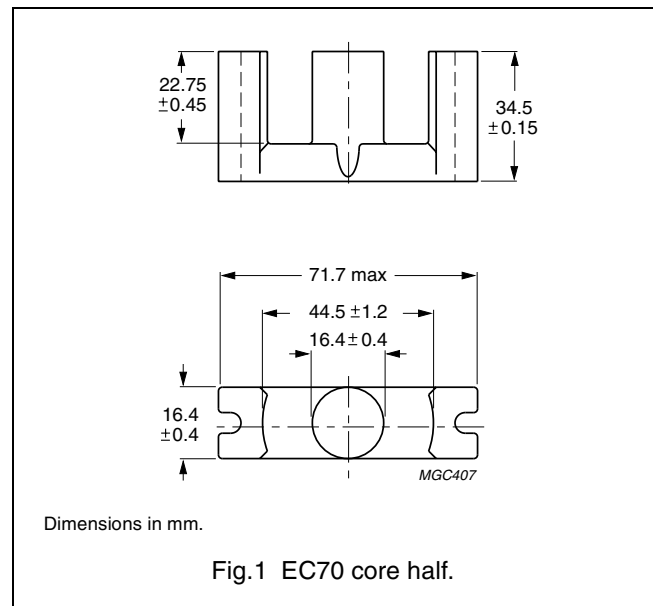

Core halves

A_L measured in combination with an non-gapped core half, unless stated otherwise.

GRADE	A_L (nH)	μ_e	TOTAL AIR GAP (μm)	TYPE NUMBER
3C81 ^{sup}	250 ± 3% ⁽¹⁾	≈ 102	≈ 1830	EC70-3C81-E250
	315 ± 3% ⁽¹⁾	≈ 130	≈ 1370	EC70-3C81-E315
	400 ± 3% ⁽¹⁾	≈ 165	≈ 1020	EC70-3C81-E400
	630 ± 5%	≈ 256	≈ 580	EC70-3C81-A630
	1000 ± 10%	≈ 406	≈ 320	EC70-3C81-A1000
	≥ 4000	≥ 1620	≈ 0	EC70-3C81
3C90 ^{sup}	250 ± 3% ⁽¹⁾	≈ 102	≈ 1830	EC70-3C90-E250
	315 ± 3% ⁽¹⁾	≈ 130	≈ 1370	EC70-3C90-E315
	400 ± 3% ⁽¹⁾	≈ 165	≈ 1020	EC70-3C90-E400
	630 ± 5%	≈ 256	≈ 580	EC70-3C90-A630
	1000 ± 10%	≈ 406	≈ 320	EC70-3C90-A1000
	3900 ± 25%	≈ 1580	≈ 0	EC70-3C90

Note

1. Measured in combination with an equal gapped core half (symmetrical air gap).

Properties of core sets under power conditions

GRADE	B (mT) at	CORE LOSS (W) at	
	H = 250 A/m; f = 25 kHz; T = 100 °C	f = 25 kHz; B = 200 mT; T = 100 °C	f = 100 kHz; B = 100 mT; T = 100 °C
3C81	≥330	≤ 8.2	–
3C90	≥330	≤ 4.9	≤ 5.1

COIL FORMERS

General data 8-slots EC70 coil former for insertable pins

PARAMETER	SPECIFICATION
Coil former material	polyamide (PA6.6), glass-reinforced, flame retardant in accordance with "UL 94V-0"; UL file number E44716(M)
Maximum operating temperature	130 °C, "IEC 60085", class B

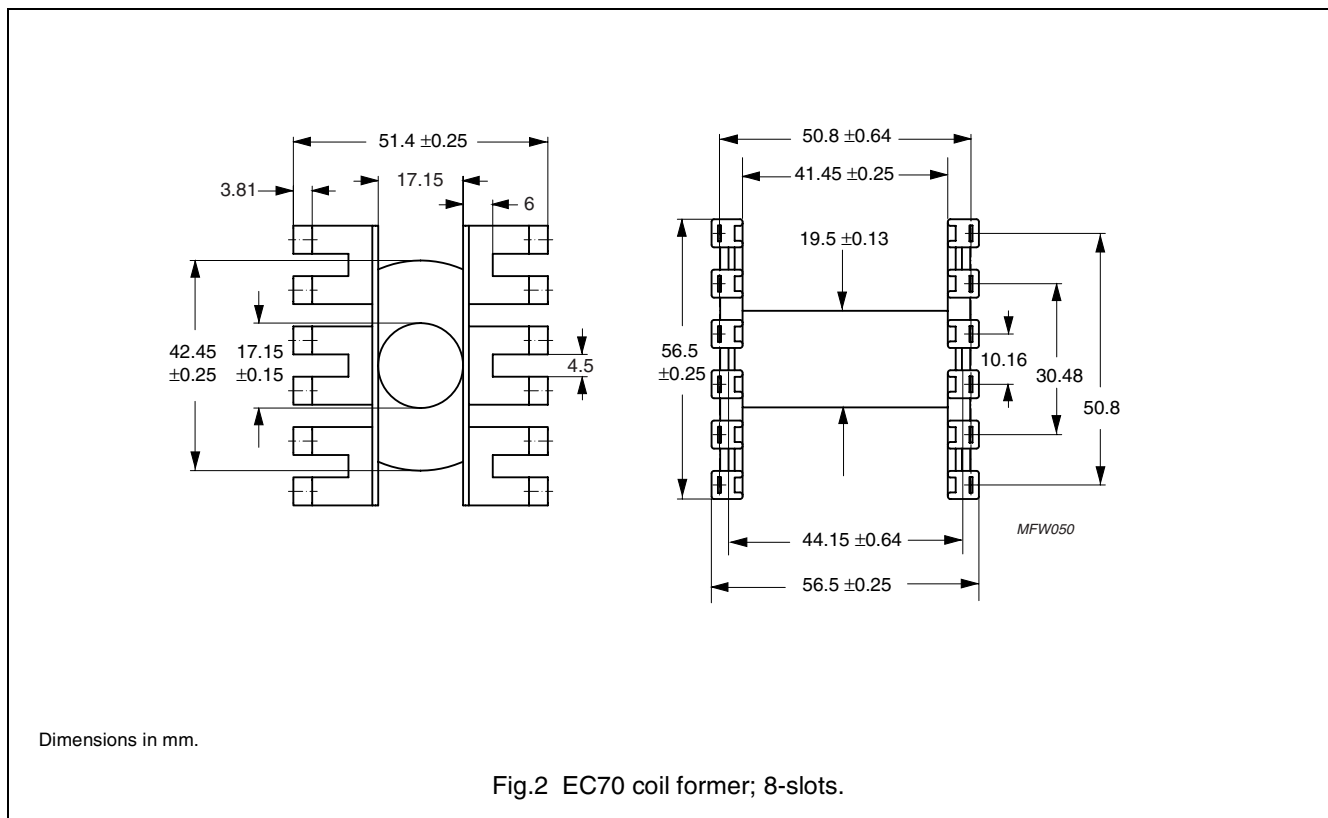

Winding data and area product for 8-slots EC70 coil former for insertable pins; see note 1

NUMBER OF SECTIONS	MINIMUM WINDING AREA (mm ²)	NOMINAL WINDING WIDTH (mm)	AVERAGE LENGTH OF TURN (mm)	AREA PRODUCT Ae x Aw (mm ⁴)	TYPE NUMBER
1	465	41.5	97.3	130000	CP-EC70-1S

Note

- Coil formers with inserted pins are available on request.

MOUNTING PARTS

General data and ordering information

ITEM	REMARKS	MOUNT	FIGURE	TYPE NUMBER
Insertable pins	solderability: "IEC 68-2-20", Part 2, Test Ta, method 1 material : copper-zinc alloy (CuZn), tin (Sn) plated	general	3	PIN-EC
		horizontal	4	PIN/H-EC
		vertical	5	PIN/V-EC70
Clamp	copper-zinc alloy (CuZn)		6	CLM/U-EC70
Base plate 4 holes	aluminium		7	BPL4-EC70

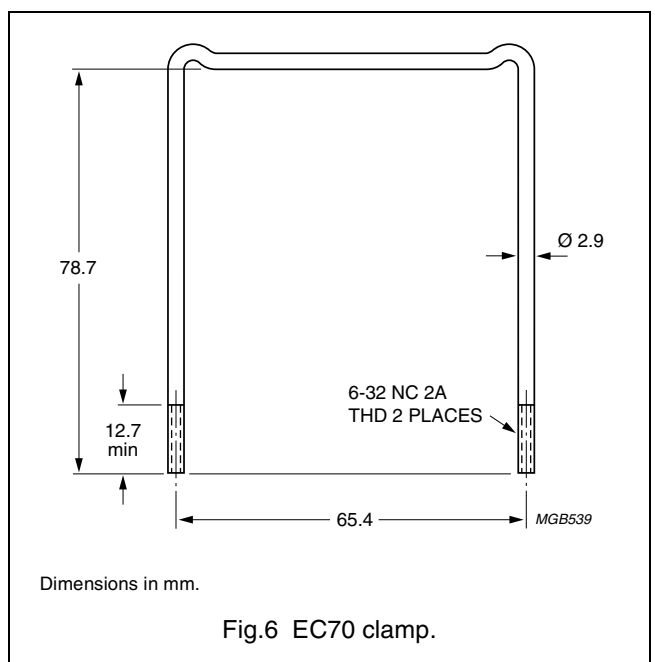
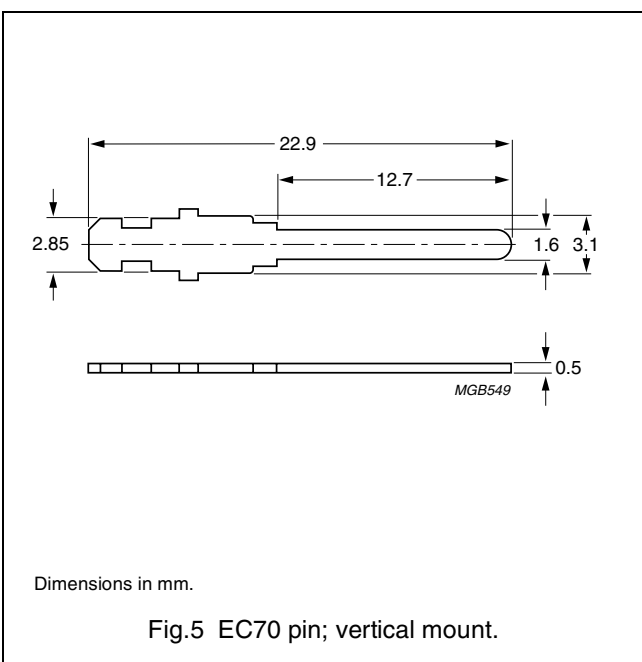
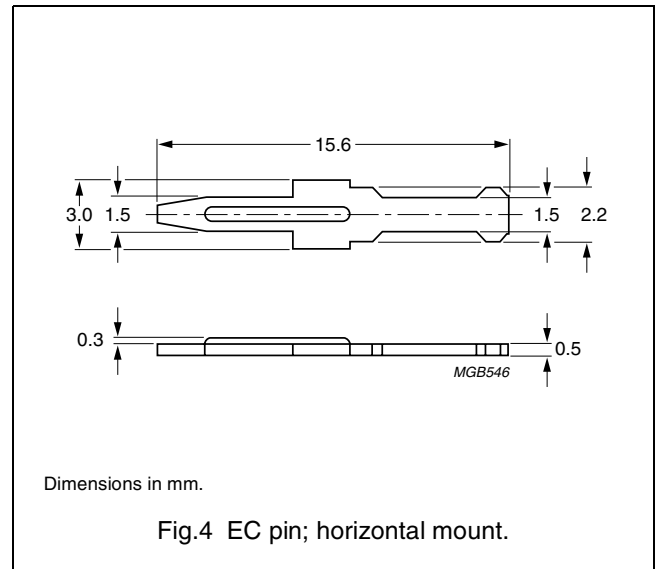
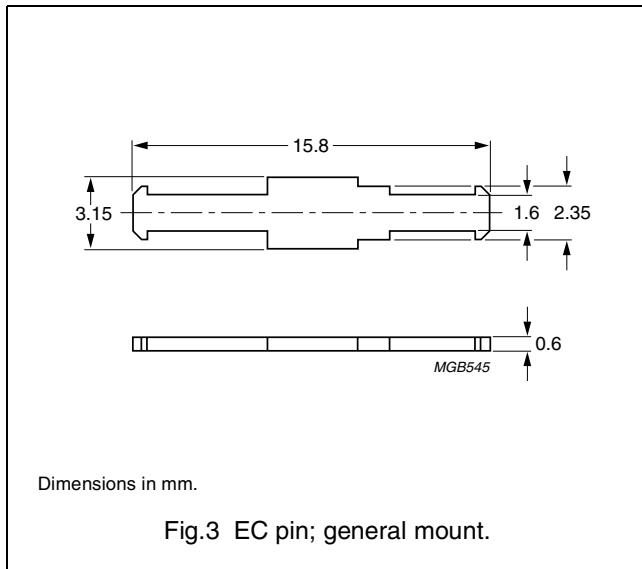

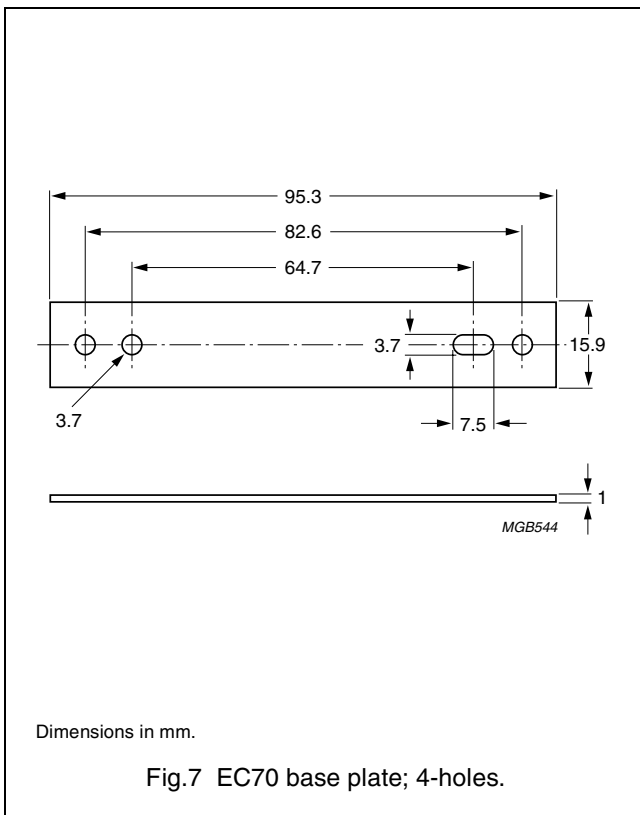



DATA SHEET STATUS DEFINITIONS

DATA SHEET STATUS	PRODUCT STATUS	DEFINITIONS
Preliminary specification	Development	This data sheet contains preliminary data. Ferroxcube reserves the right to make changes at any time without notice in order to improve design and supply the best possible product.
Product specification	Production	This data sheet contains final specifications. Ferroxcube reserves the right to make changes at any time without notice in order to improve design and supply the best possible product.

DISCLAIMER

Life support applications — These products are not designed for use in life support appliances, devices, or systems where malfunction of these products can reasonably be expected to result in personal injury. Ferroxcube customers using or selling these products for use in such applications do so at their own risk and agree to fully indemnify Ferroxcube for any damages resulting from such application.

PRODUCT STATUS DEFINITIONS

STATUS	INDICATION	DEFINITION
Prototype		These are products that have been made as development samples for the purposes of technical evaluation only. The data for these types is provisional and is subject to change.
Design-in		These products are recommended for new designs.
Preferred		These products are recommended for use in current designs and are available via our sales channels.
Support		These products are not recommended for new designs and may not be available through all of our sales channels. Customers are advised to check for availability.