

Soft Ferrites

P cores and accessories

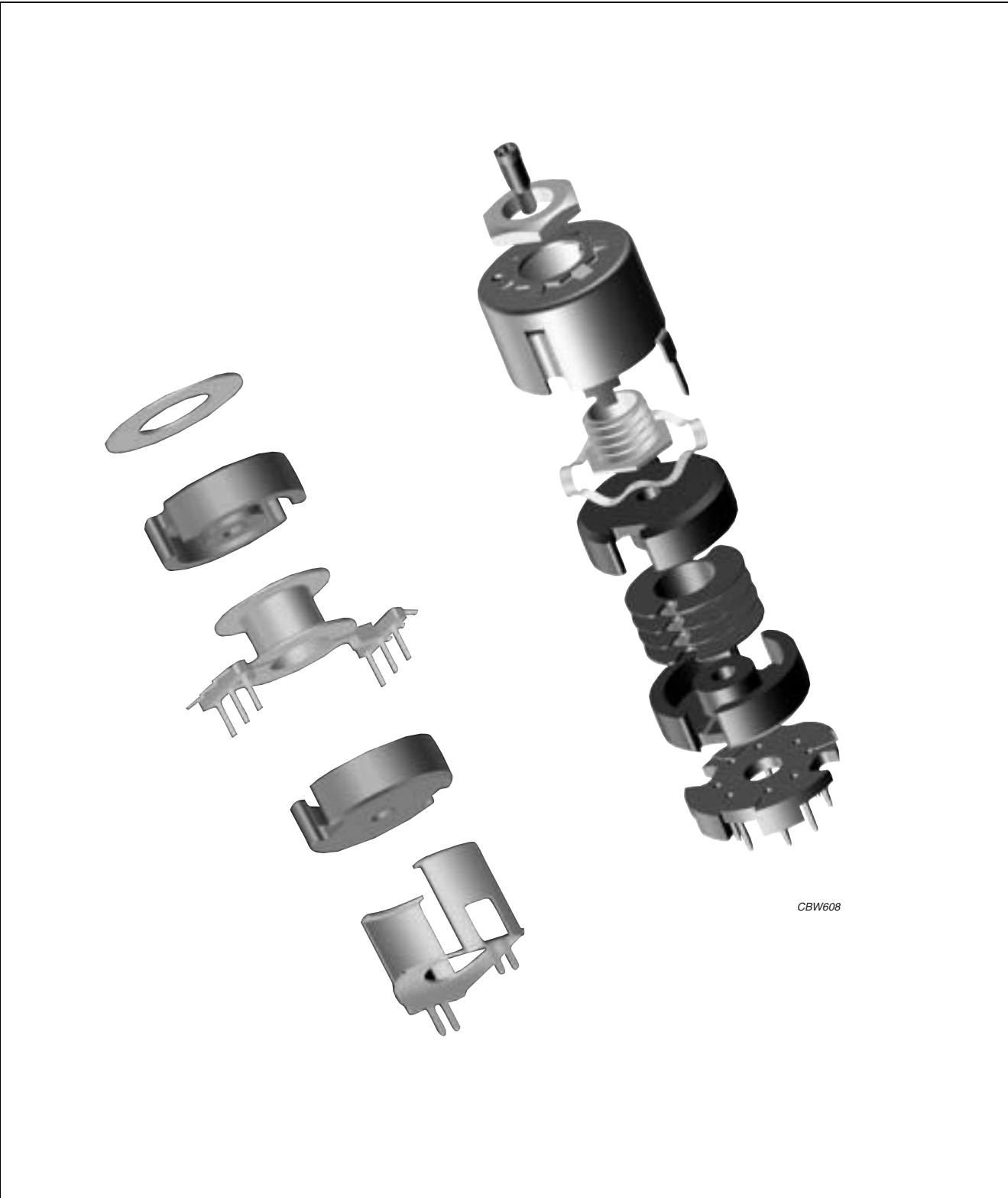

CBW608

Soft Ferrites

P cores and accessories

PRODUCT OVERVIEW AND TYPE NUMBER STRUCTURE

Product overview P cores

CORE TYPE	V _e (mm ³)	A _e (mm ²)	MASS (g)
P9/5	126	10.1	0.8
P11/7	251	16.2	1.8
P11/7/l	309	19.0	1.9
P14/8	495	25.1	3.2
P14/18/l	628	29.9	3.5
P18/11	1 120	43.3	6.0
P18/11/l	1 270	47.5	7
P22/13	2000	63.4	12
P22/13/l	2460	73.4	13
P26/16	3530	93.9	20
P26/16/l	4370	110	21
P30/19	6190	137	34
P36/22	10700	202	54
P42/29	18 200	265	104
P66/56	88200	717	550

• In accordance with IEC 62317, part 2.

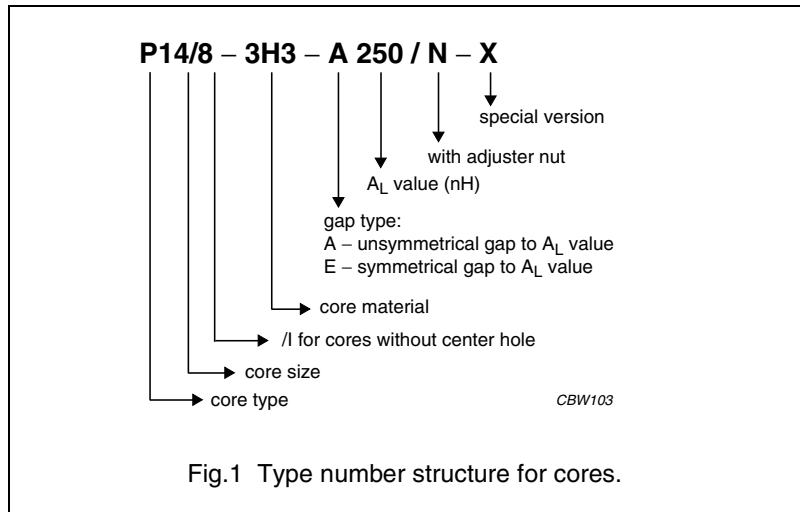

Fig.1 Type number structure for cores.

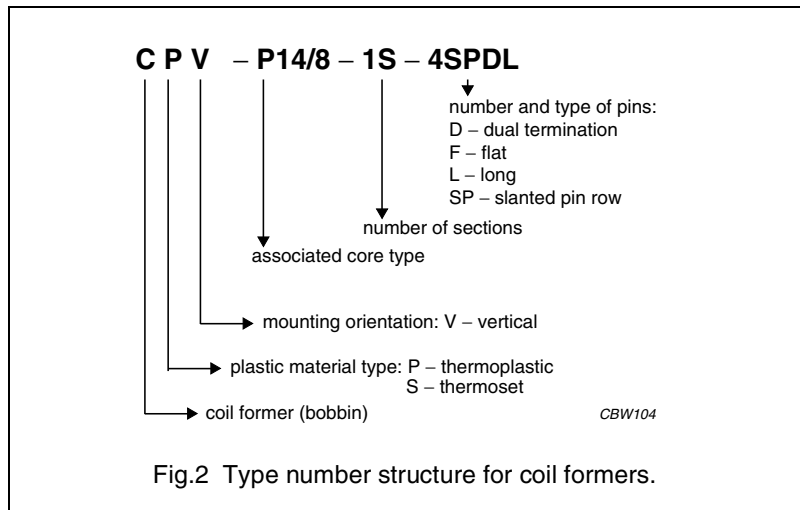

Fig.2 Type number structure for coil formers.

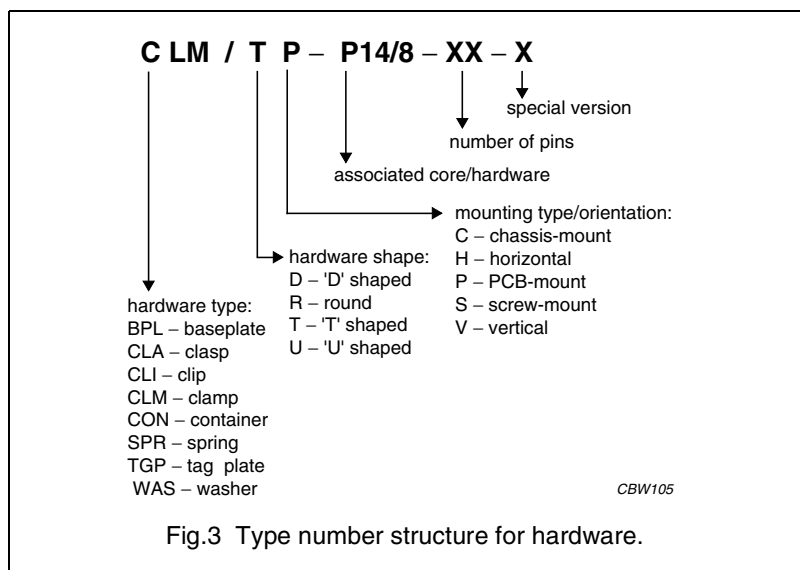

Fig.3 Type number structure for hardware.