

# DATA SHEET

**PT14/8**

**PT, PTS, PTS/I cores and  
accessories**

Supersedes data of September 2004

2008 Sep 01

**CORE SETS**

**Effective core parameters**

SYMBOL	PARAMETER	VALUE	UNIT
$\Sigma(l/A)$	core factor (C1)	0.910	mm <sup>-1</sup>
$V_e$	effective volume	492	mm <sup>3</sup>
$l_e$	effective length	21.1	mm
$A_e$	effective area	23.3	mm <sup>2</sup>
$A_{min}$	minimum area	19.9	mm <sup>2</sup>
m	mass of set	≈ 2.8	g

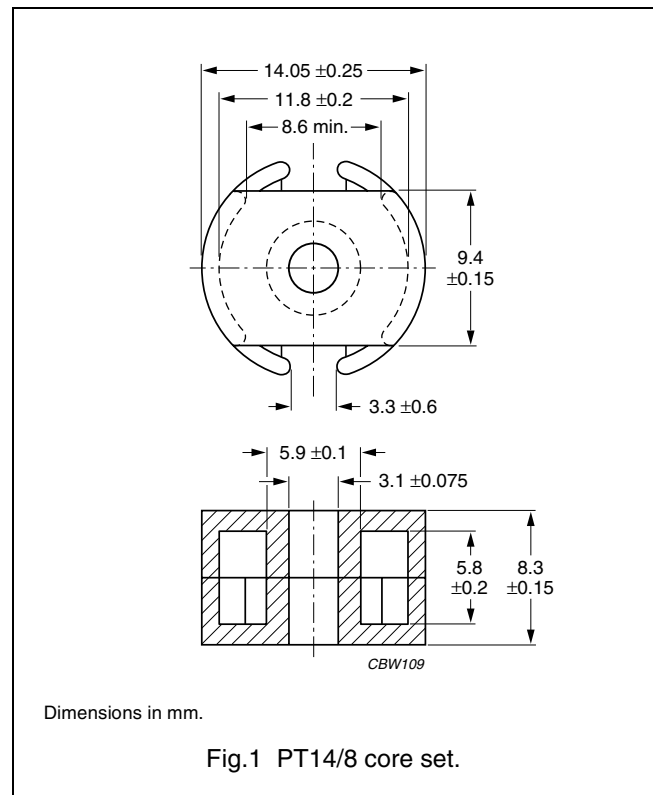

**Core sets for general purpose transformers and power applications**

Clamping force for  $A_L$  measurements, 15 ± 15 N.

GRADE	$A_L$ (nH)	$\mu_e$	AIR GAP ( $\mu$ m)	TYPE NUMBER
3C81 <sup>sup</sup>	63 ± 3%	≈ 45	≈ 630	PT14/8-3C81-A63
	100 ± 3%	≈ 72	≈ 360	PT14/8-3C81-A100
	160 ± 3%	≈ 115	≈ 210	PT14/8-3C81-A160
	250 ± 3%	≈ 180	≈ 120	PT14/8-3C81-A250
	315 ± 5%	≈ 227	≈ 90	PT14/8-3C81-A315
	2400 ± 25%	≈ 1730	≈ 0	PT14/8-3C81
3C91 <sup>sup</sup>	2400 ± 25%	≈ 1730	≈ 0	PT14/8-3C91
3F3 <sup>sup</sup>	63 ± 3%	≈ 45	≈ 630	PT14/8-3F3-A63
	100 ± 3%	≈ 72	≈ 360	PT14/8-3F3-A100
	160 ± 3%	≈ 115	≈ 210	PT14/8-3F3-A160
	250 ± 3%	≈ 180	≈ 120	PT14/8-3F3-A250
	315 ± 5%	≈ 227	≈ 90	PT14/8-3F3-A315
	1650 ± 25%	≈ 1190	≈ 0	PT14/8-3F3

## PT, PTS, PTS/I cores and accessories

PT14/8  
(1408TS)**Core sets of high permeability grades**Clamping force for  $A_L$  measurements,  $15 \pm 5$  N.

GRADE	$A_L$ (nH)	$\mu_e$	AIR GAP ( $\mu\text{m}$ )	TYPE NUMBER
3E27 <sup>sup</sup>	$4500 \pm 25\%$	$\approx 3240$	$\approx 0$	PT14/8-3E27

**Properties of core sets under power conditions**

GRADE	B (mT) at	CORE LOSS (W) at			
	H = 250 A/m; f = 25 kHz; T = 100 °C	f = 25 kHz; $\hat{B}$ = 200 mT; T = 100 °C	f = 100 kHz; $\hat{B}$ = 100 mT; T = 100 °C	f = 100 kHz; $\hat{B}$ = 200 mT; T = 100 °C	f = 400 kHz; $\hat{B}$ = 50 mT; T = 100 °C
3C81	$\geq 320$	$\leq 0.11$	–	–	–
3C91	$\geq 320$	–	$\leq 0.03^{(1)}$	$\leq 0.22^{(1)}$	–
3F3	$\geq 315$	–	$\leq 0.06$	–	$\leq 0.1$

**Note**

1. Measured at 60 °C.

**COIL FORMERS**

**General data 6-pins PT14/8 coil former**

PARAMETER	SPECIFICATION
Coil former material	polyamide (PA), glass-reinforced, flame retardant in accordance with "UL 94V-0"; UL file number E41938(M)
Pin material	copper-tin alloy (CuSn), tin (Sn) plated
Maximum operating temperature	130 °C, "IEC 60085" class B
Resistance to soldering heat	"IEC 60068-2-20", Part 2, Test Tb, method 1B, 350 °C, 3.5 s
Solderability	"IEC 60068-2-20", Part 2, Test Ta, method 1

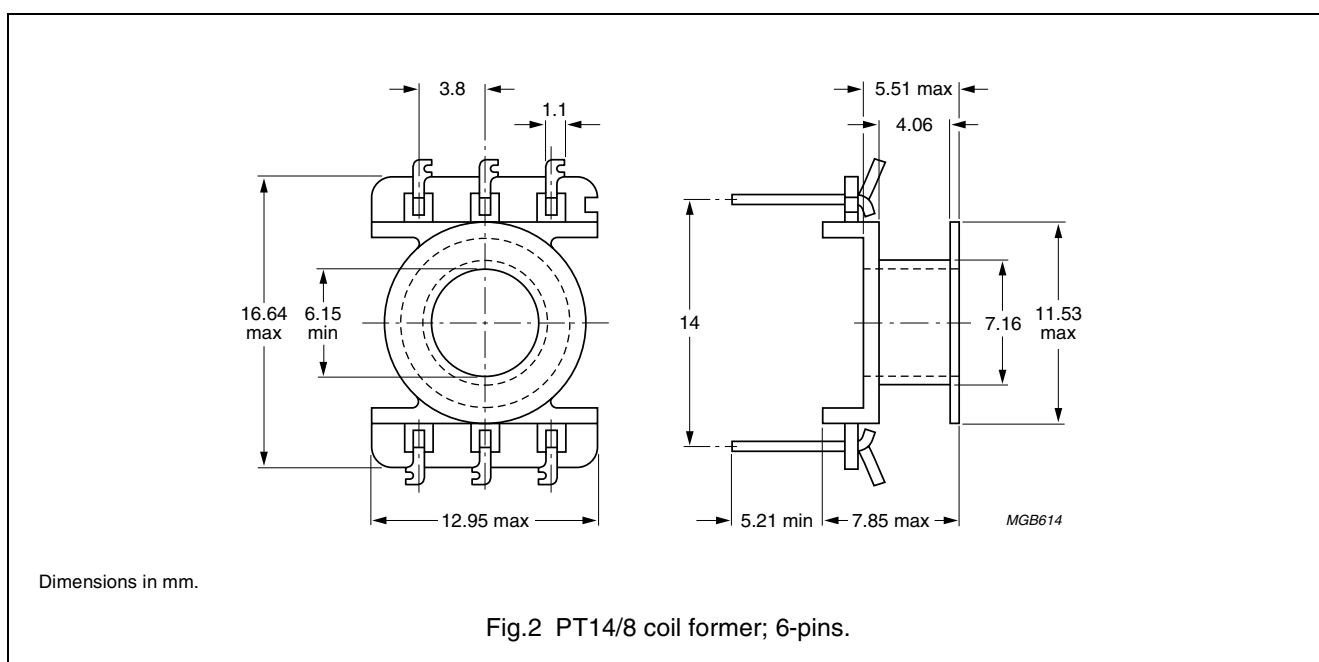

**Winding data and area product for 6-pins PT14/8 coil former**

NUMBER OF SECTIONS	MINIMUM WINDING AREA (mm <sup>2</sup> )	NOMINAL WINDING WIDTH (mm)	AVERAGE LENGTH OF TURN (mm)	AREA PRODUCT Ae x Aw (mm <sup>4</sup> )	TYPE NUMBER
1	7.9	4.1	29.2	184	CPV-PT14/8-1S-6P

Additional coil formers and mounting parts are those of "P14/8", but "area product" is different.

**Winding data and area product (for PT14/8) for CP-P14/8 coil former**

NUMBER OF SECTIONS	WINDING AREA (mm <sup>2</sup> )	MINIMUM WINDING WIDTH (mm)	AVERAGE LENGTH OF TURN (mm)	AREA PRODUCT Ae x Aw (mm <sup>4</sup> )	TYPE NUMBER
1	8.8	4.1	28.9	205	CP-P14/8-1S
2	2 x 4.0	2 x 1.85	28.9	2 x 93.2	CP-P14/8-2S

## PT, PTS, PTS/I cores and accessories

PT14/8  
(1408TS)

## Winding data and area product (for PT14/8) for CP-P14/8-A coil former

NUMBER OF SECTIONS	MINIMUM WINDING AREA (mm <sup>2</sup> )	NOMINAL WINDING WIDTH (mm)	AVERAGE LENGTH OF TURN (mm)	AREA PRODUCT Ae x Aw (mm <sup>4</sup> )	TYPE NUMBER
1	9.4	4.5	29.0	219	CP-P14/8-1S-A
2	2 x 4.32	2 x 2.0	29.0	2 x 101	CP-P14/8-2S-A
3	3 x 2.19	3 x 1.2	29.0	3 x 51.0	CP-P14/8-3S-A

## Winding data and area product (for PT14/8) for 4-pins P14/8 coil former for PCB mounting

NUMBER OF SECTIONS	MINIMUM WINDING AREA (mm <sup>2</sup> )	NOMINAL WINDING WIDTH (mm)	AVERAGE LENGTH OF TURN (mm)	LENGTH OF PINS (mm)	AREA PRODUCT Ae x Aw (mm <sup>4</sup> )	TYPE NUMBER
1	8.65	4.4	29.0	4.4	202	CPV-P14/8-1S-4SPD
1	8.65	4.4	29.0	6.8	202	CPV-P14/8-1S-4SPDL
2	2 x 3.87	2 x 2.0	29.0	4.4	2 x 90.2	CPV-P14/8-2S-4SPD
2	2 x 3.87	2 x 2.0	29.0	6.8	2 x 90.2	CPV-P14/8-2S-4SPDL

## Winding data and area product (for PT14/8) for 6-pins P14/8 coil former for PCB mounting

NUMBER OF SECTIONS	MINIMUM WINDING AREA (mm <sup>2</sup> )	NOMINAL WINDING WIDTH (mm)	AVERAGE LENGTH OF TURN (mm)	LENGTH OF PINS (mm)	AREA PRODUCT Ae x Aw (mm <sup>4</sup> )	TYPE NUMBER
1	8.65	4.4	29.0	4.4	202	CPV-P14/8-1S-6PD
1	8.65	4.4	29.0	6.8	202	CPV-P14/8-1S-6PDL
2	2 x 3.87	2 x 2.0	29.0	4.4	2 x 90.2	CPV-P14/8-2S-6PD
2	2 x 3.87	2 x 2.0	29.0	6.8	2 x 90.2	CPV-P14/8-2S-6PDL

**DATA SHEET STATUS DEFINITIONS**

DATA SHEET STATUS	PRODUCT STATUS	DEFINITIONS
Preliminary specification	Development	This data sheet contains preliminary data. Ferroxcube reserves the right to make changes at any time without notice in order to improve design and supply the best possible product.
Product specification	Production	This data sheet contains final specifications. Ferroxcube reserves the right to make changes at any time without notice in order to improve design and supply the best possible product.

**DISCLAIMER**

**Life support applications** — These products are not designed for use in life support appliances, devices, or systems where malfunction of these products can reasonably be expected to result in personal injury. Ferroxcube customers using or selling these products for use in such applications do so at their own risk and agree to fully indemnify Ferroxcube for any damages resulting from such application.

**PRODUCT STATUS DEFINITIONS**

STATUS	INDICATION	DEFINITION
<b>Prototype</b>		These are products that have been made as development samples for the purposes of technical evaluation only. The data for these types is provisional and is subject to change.
<b>Design-in</b>		These products are recommended for new designs.
<b>Preferred</b>		These products are recommended for use in current designs and are available via our sales channels.
<b>Support</b>		These products are <b>not</b> recommended for new designs and may not be available through all of our sales channels. Customers are advised to check for availability.