

DATA SHEET

SMD beads
EMI-suppression products

Supersedes data of September 2004

2008 Sep 01

SMD BEADS FOR EMI SUPPRESSION

General data

ITEM	SPECIFICATION
Strip material	copper (Cu), tin (Sn) plated
Solderability	"IEC 60068-2-58", Part 2, Test Ta, method 1
Taping method	"IEC 60286-3", "EIA 481-1" and "EIA 481-2"

Grades, parameters and type numbers

GRADE	$ Z_{typ} ^{(1)}$ (Ω)	at f (MHz)	TYPE NUMBER
BDS 3/1.8/5.3; mass ≈ 0.1 g⁽²⁾			
3S1	28	10	BDS 3/1.8/5.3-3S1
	33	25	
	25	100	
4S2	25	25	BDS 3/1.8/5.3-4S2
	38	100	
	45	300	
BDS 3/3/4.6; mass ≈ 0.15 g⁽²⁾			
3S1	25	3	BDS3/3/4.6-3S1
	45	10	
	35	25	
4S2	30	25	BDS3/3/4.6-4S2
	50	100	
	55	300	
BDS 3/3/8.9; mass ≈ 0.3 g⁽³⁾			
3S1	55	3	BDS 3/3/8.9-3S1
	80	10	
	55	25	
4S2	65	25	BDS 3/3/8.9-4S2
	100	100	
	110	300	
BDS 4.6/3/8.9; mass ≈ 0.5 g⁽³⁾			
4S2	65	25	BDS 4.6/3/8.9-4S2
	100	100	
	110	300	

Note

1. Typical values, $|Z|_{min}$ is -20% .
2. DC resistance < 0.6 m Ω .
3. DC resistance < 1.0 m Ω

Mechanical data

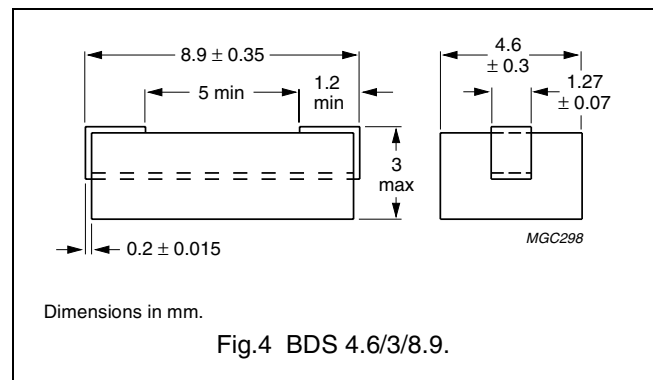
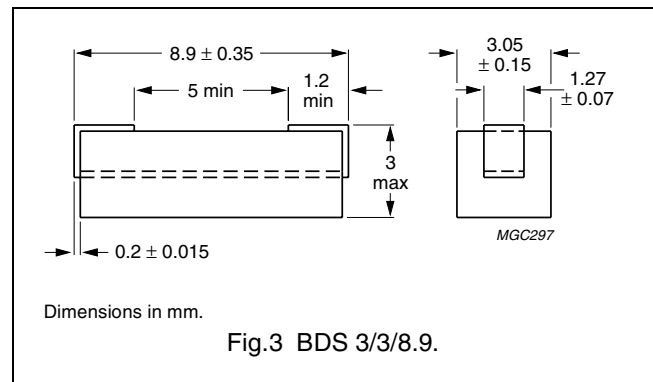
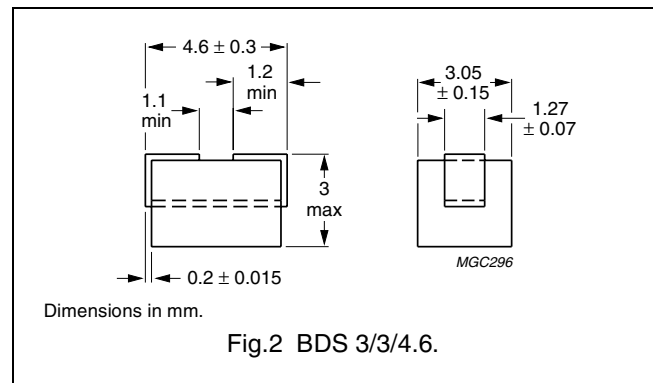
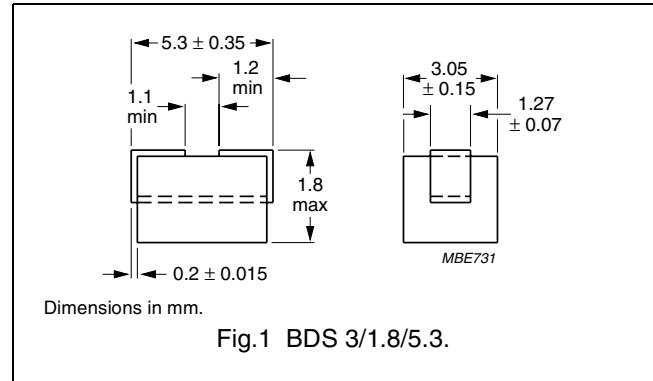

RECOMMENDED DIMENSIONS OF SOLDER LANDS

Table 1 Reflow soldering

SIZE	DIMENSIONS (mm)			
	A	B	C	D
BDS 3/1.8/5.3	2.8	7.2	2.2	3.3
BDS 3/3/4.6	2.8	6.4	1.8	3.3
BDS 3/3/8.9	7.0	10.8	1.9	3.3
BDS 4.6/3/8.9	7.0	10.8	1.9	3.3

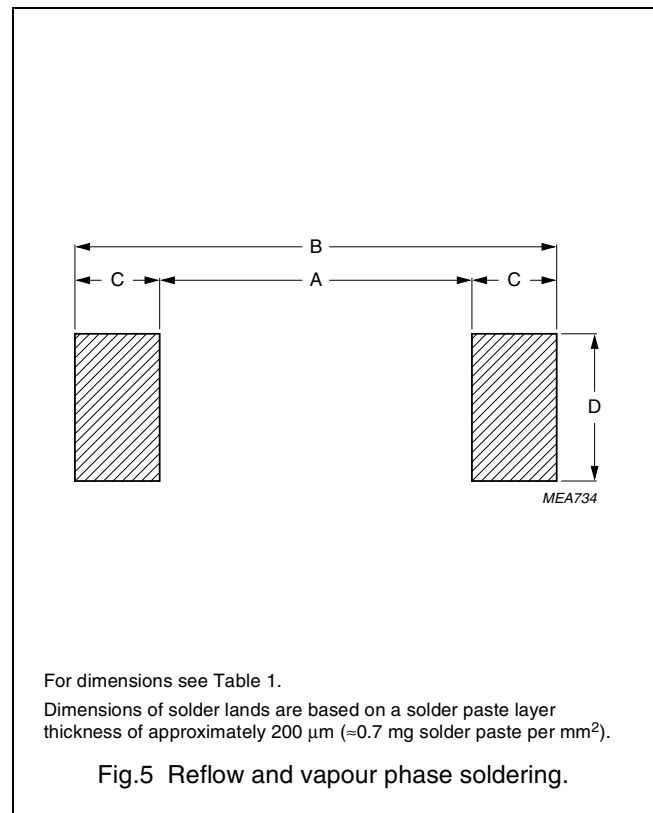
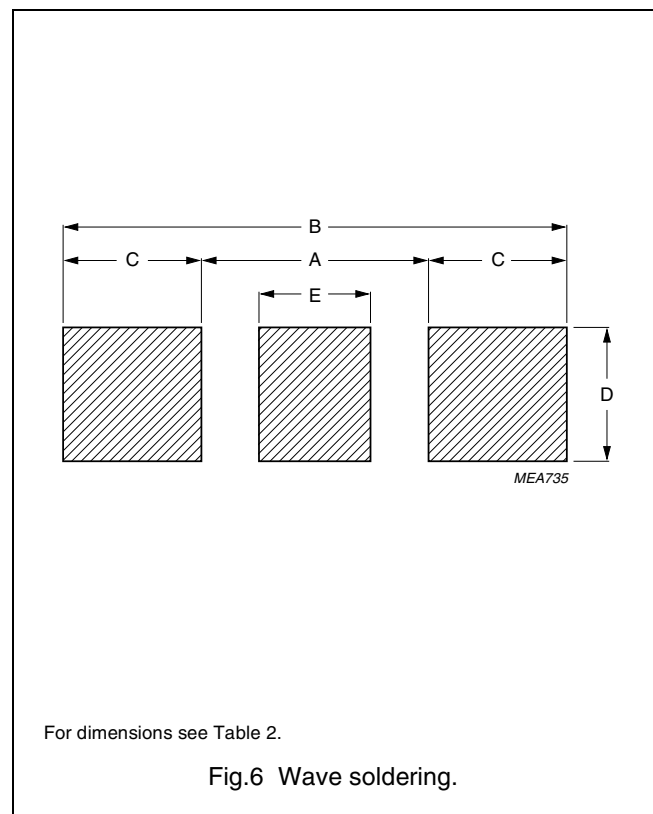

Table 2 Wave soldering

SIZE	DIMENSIONS (mm)				
	A	B	C	D	E
BDS 3/1.8/5.3	2.0	7.2	2.6	3.0	0.8
BDS 3/3/4.6	2.0	6.4	2.2	3.0	0.8
BDS 3/3/8.9	6.0	12.2	3.1	3.0	2.5
BDS 4.6/3/8.9	6.0	12.2	3.1	3.0	2.5



Soldering profiles

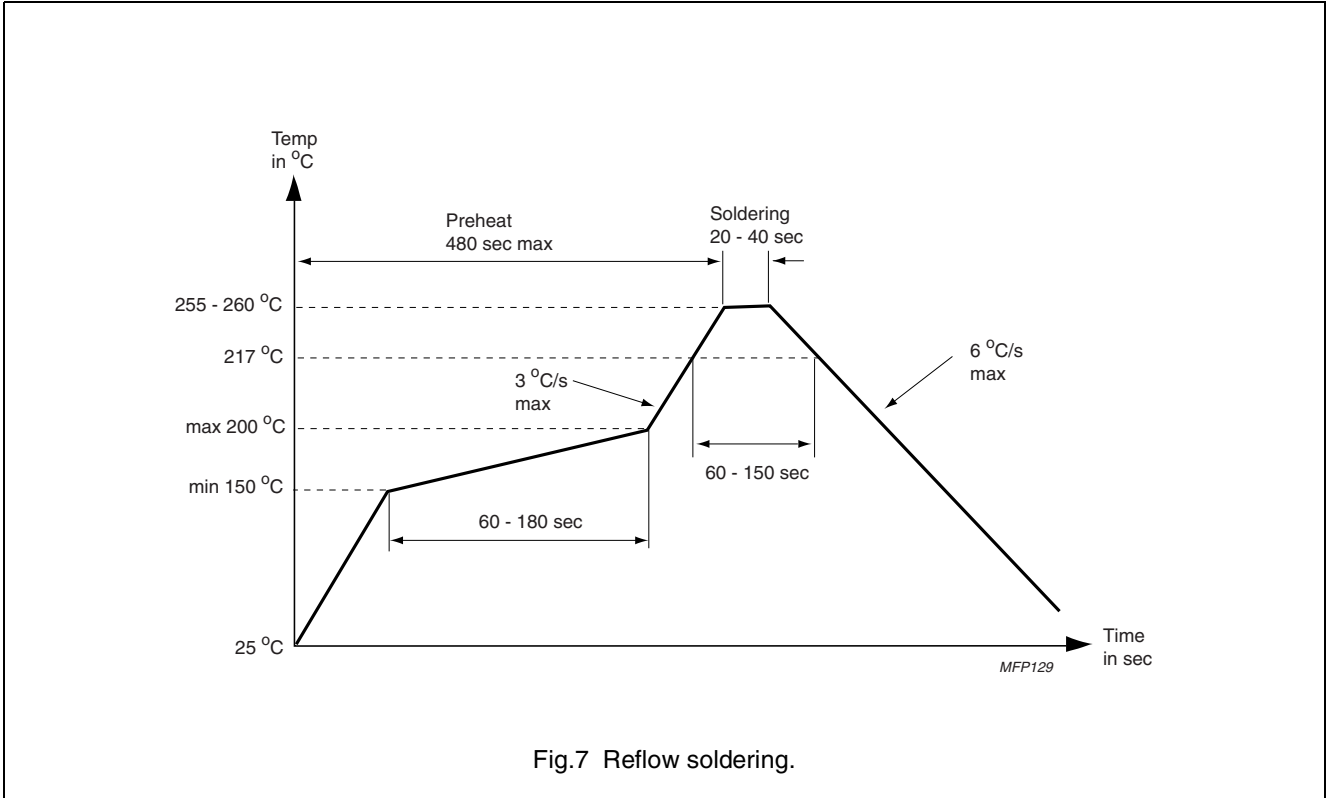
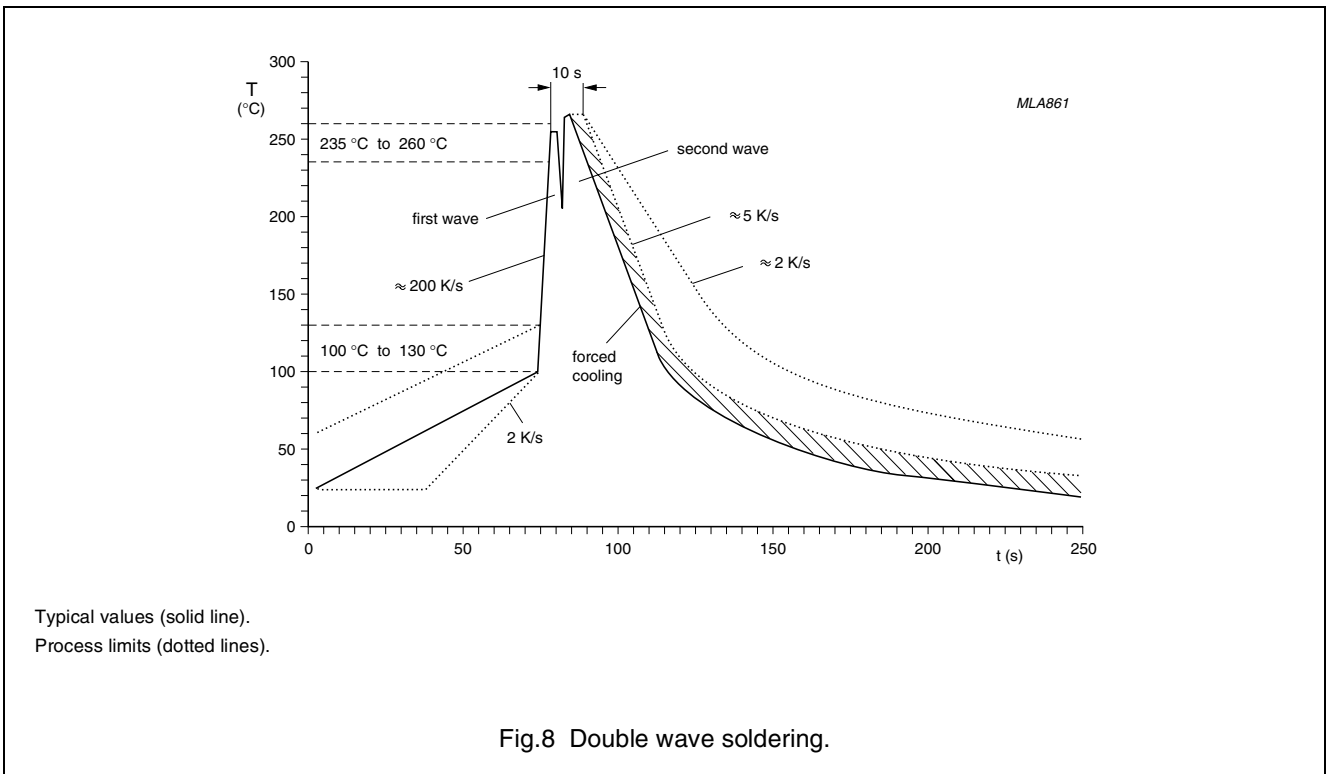

Fig.7 Reflow soldering.



Typical values (solid line).
Process limits (dotted lines).

Fig.8 Double wave soldering.

BLISTER TAPE AND REEL DIMENSIONS

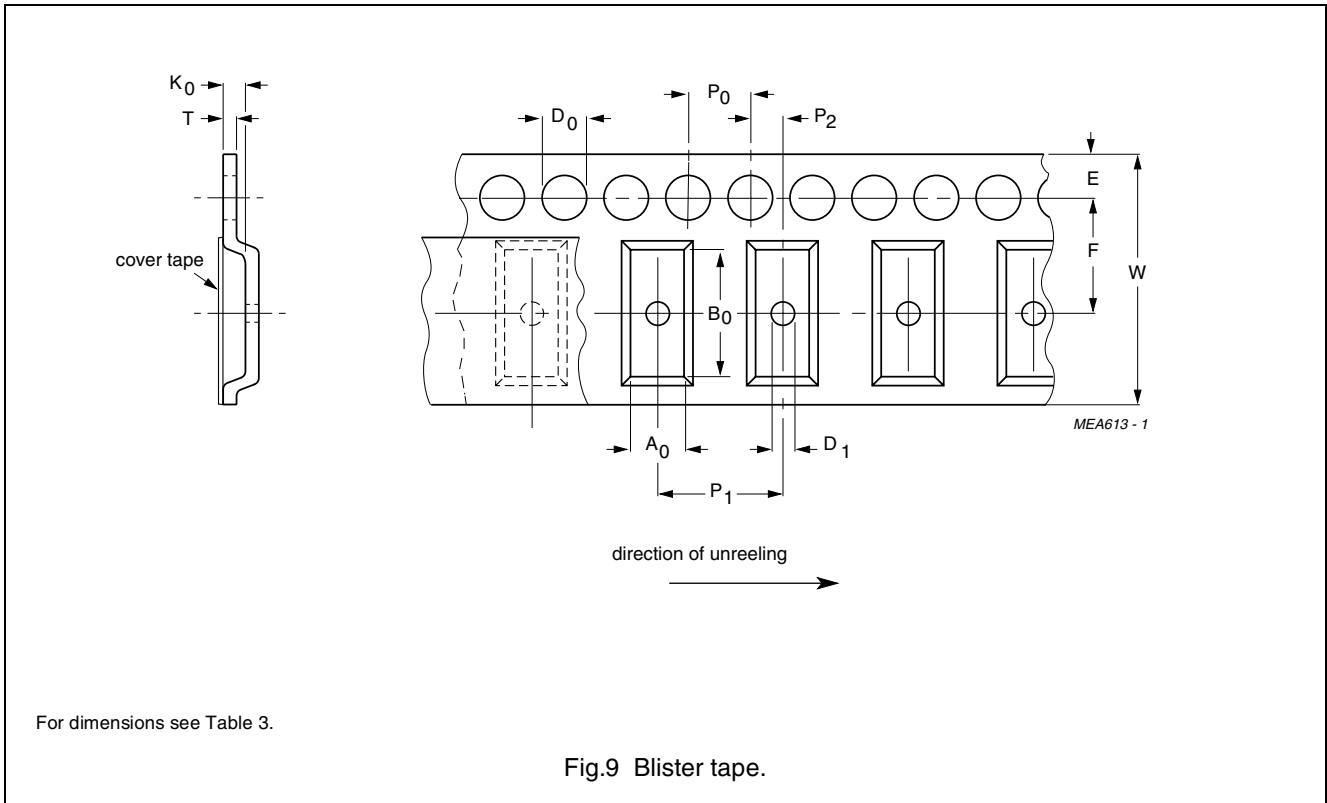

Table 3 Physical dimensions of blister tape; see Fig.9

SIZE	DIMENSIONS (mm)			
	BDS3/1.8/5.3	BDS3/3/4.6	BDS3/3/8.9	BDS4.6/3/8.9
A_0	3.25 ± 0.1	3.45 ± 0.1	3.45 ± 0.1	5.1 ± 0.1
B_0	5.85 ± 0.1	5.1 ± 0.1	9.4 ± 0.1	9.4 ± 0.1
K_0	2.0 ± 0.1	3.1 ± 0.1	3.1 ± 0.1	3.1 ± 0.1
T	0.3 ± 0.05	$0.25 \pm 10\%$	0.35 ± 0.05	0.3 ± 0.05
W	12.0 ± 0.3	12.0 ± 0.3	16.0 ± 0.3	16.0 ± 0.3
E	1.75 ± 0.1	1.75 ± 0.1	1.75 ± 0.1	1.75 ± 0.1
F	5.5 ± 0.05	5.5 ± 0.05	7.5 ± 0.1	7.5 ± 0.1
D_0	$1.5 + 0.1$	$1.5 + 0.1$	$1.5 + 0.1$	$1.5 + 0.1$
D_1	≥ 1.5	≥ 1.5	≥ 1.5	≥ 1.5
P_0	4.0 ± 0.1	4.0 ± 0.1	4.0 ± 0.1	4.0 ± 0.1
P_1	8.0 ± 0.1	8.0 ± 0.1	8.0 ± 0.1	8.0 ± 0.1
P_2	2.0 ± 0.1	2.0 ± 0.05	2.0 ± 0.1	2.0 ± 0.1

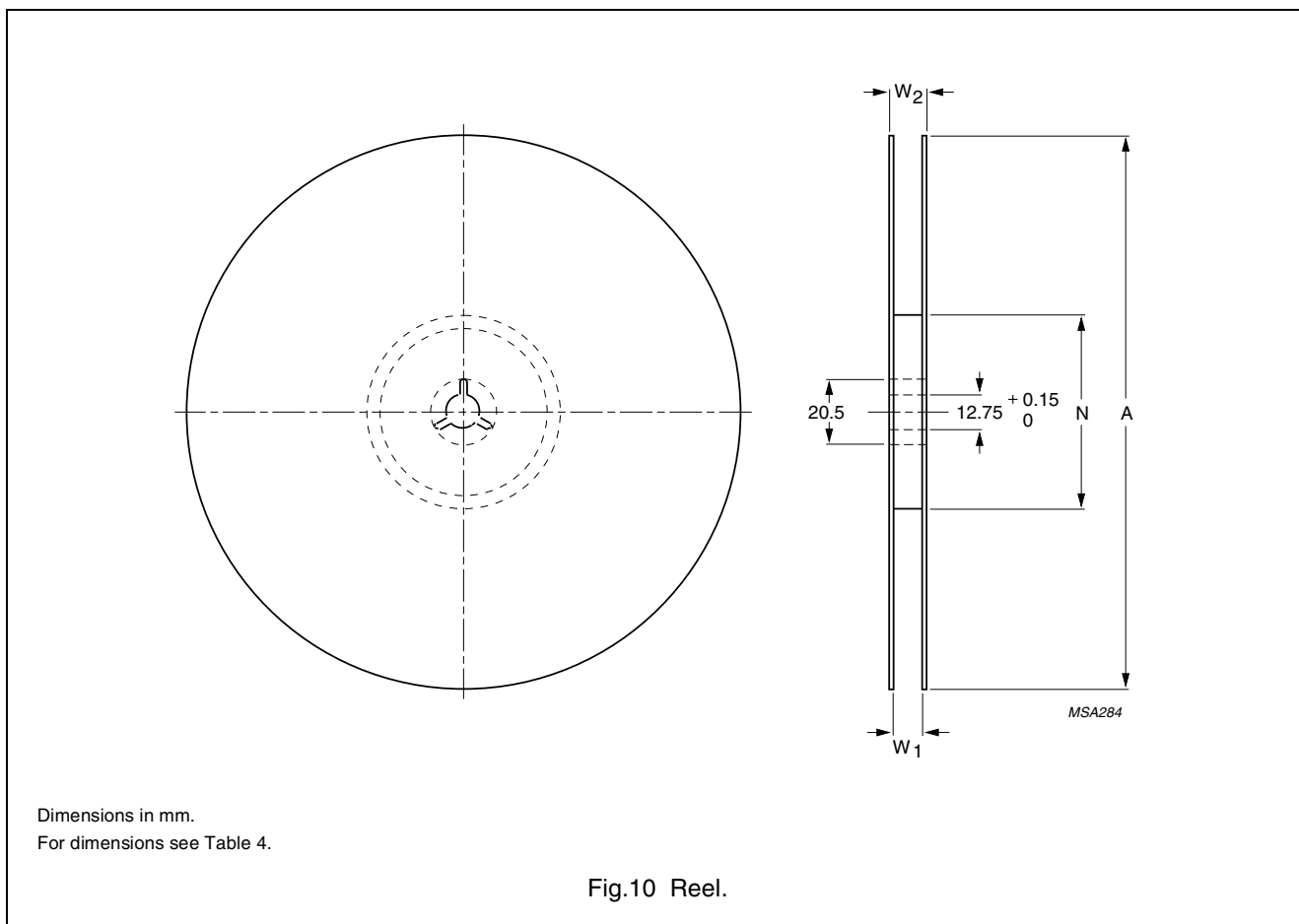

Table 4 Reel dimensions; see Fig.10

SIZE	DIMENSIONS (mm)			
	A	N	W ₁	W ₂
12	330	100 ±5	12.4	≤16.4
16	330	100 ±5	16.4	≤20.4



DATA SHEET STATUS DEFINITIONS

DATA SHEET STATUS	PRODUCT STATUS	DEFINITIONS
Preliminary specification	Development	This data sheet contains preliminary data. Ferroxcube reserves the right to make changes at any time without notice in order to improve design and supply the best possible product.
Product specification	Production	This data sheet contains final specifications. Ferroxcube reserves the right to make changes at any time without notice in order to improve design and supply the best possible product.

DISCLAIMER

Life support applications — These products are not designed for use in life support appliances, devices, or systems where malfunction of these products can reasonably be expected to result in personal injury. Ferroxcube customers using or selling these products for use in such applications do so at their own risk and agree to fully indemnify Ferroxcube for any damages resulting from such application.

PRODUCT STATUS DEFINITIONS

STATUS	INDICATION	DEFINITION
Prototype		These are products that have been made as development samples for the purposes of technical evaluation only. The data for these types is provisional and is subject to change.
Design-in		These products are recommended for new designs.
Preferred		These products are recommended for use in current designs and are available via our sales channels.
Support		These products are not recommended for new designs and may not be available through all of our sales channels. Customers are advised to check for availability.